

Electrical Schematic Diagram of SITRAK-C7H Vehicles (Nano+TFT) (Ver. 2022-01)-1

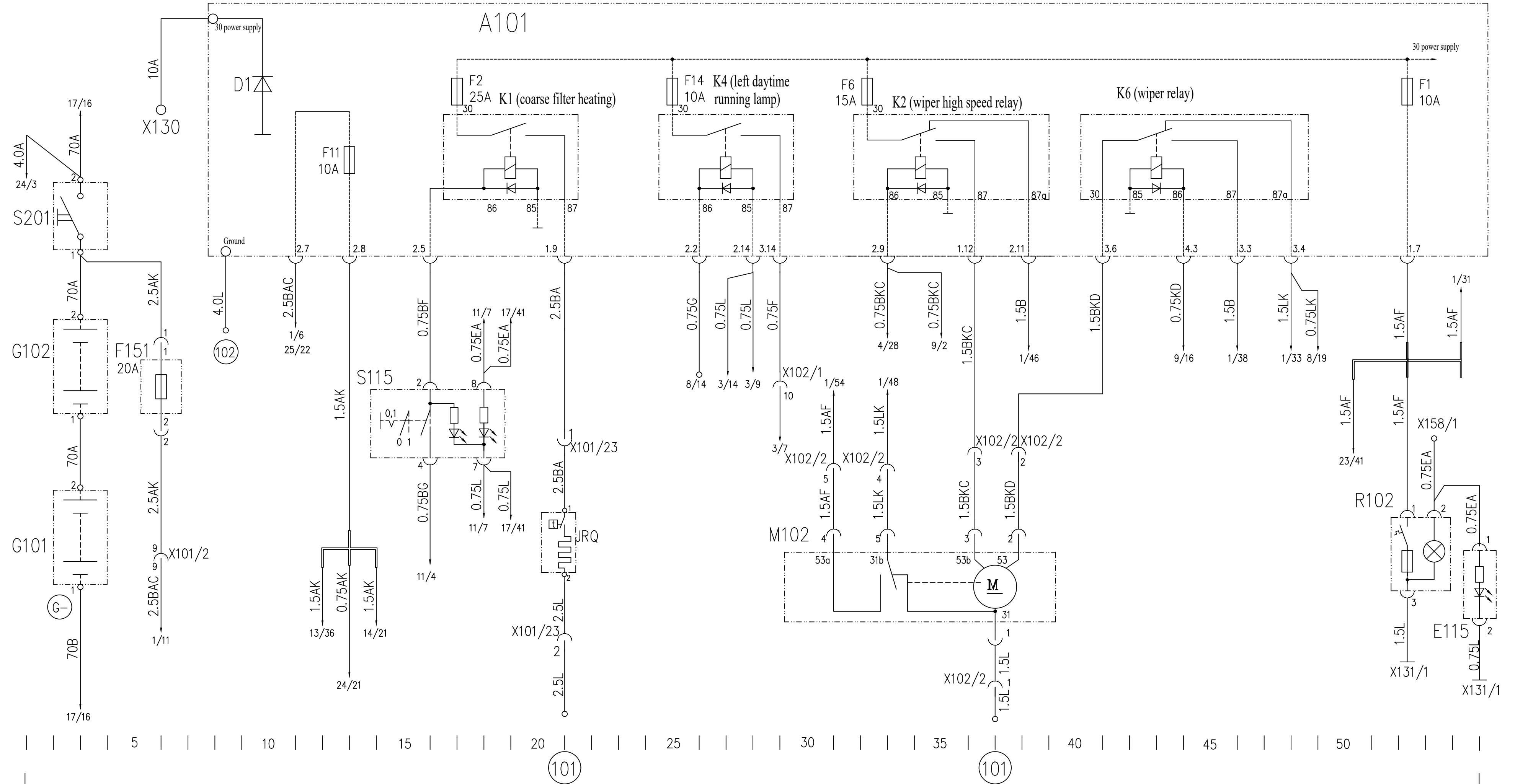

A101	Electrical junction box	K1	Fuel heating relay	F14	10A K4 relay fuse
G101	Battery I	K2	Wiper high-speed relay	X131/1	Splitter at bonding point in cab
G102	Battery II	K4	ADR D + relay	X158/1	Symbol lighting power splitter
S201	Main mechanical power switch	K6	Wiper low-speed relay	X150/1	15# power splitter
M102	Wiper motor	F1	Cigar lighter fuse	S115	Coarse filter heating switch
R102	24V cigar lighter	F2	25A coarse filter heating relay fuse	JRQ	Coarse filter heater
F151	Primary electric fuse	F6	15A wiper high-speed relay fuse	E115	Ash tray lighting lamp
D1	Diode	F11	10A constant power fuse		

⑩ Instrument-side bonding point

Central electrical junction box, power system, wiper motor, cigarette lighter

This electrical schematic diagram shows the technical status of this model as of July 30, 2022. Subject to change without prior notice.

Mark	No. of Pieces	File No.	Signature	Date

DSGN				
REWD				
CHKD				
STD.				
Process				
CTSG				
APPR				

Drawing Mark	Qty.	Scale
Trial	Small	Finished
page(s) in total		Page

China National heavy Duty Truck Group Co., Ltd.

Electrical Schematic Diagram of SITRAK-C7H Vehicles (Nano+TFT) (Ver. 2022-01)-2

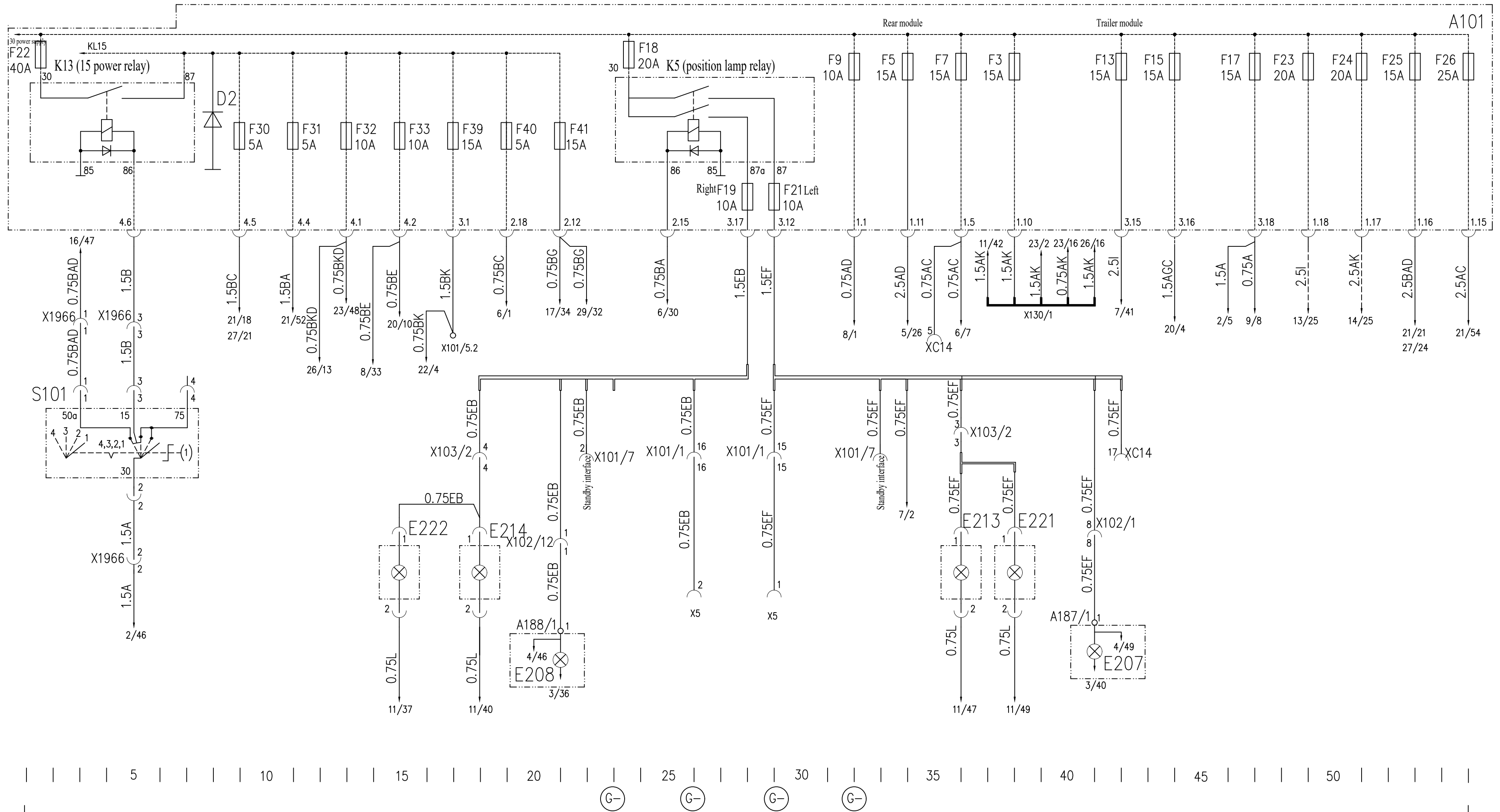

A101	Electrical junction box	F13	Trailer module fuse	F25	Tractor ABS30 electric fuse	E207, E208	Left and right front position lamps
D2	Diode	F15	TCU fuse	F26	Trailer ABS30 electric fuse	E213, E214	Left and right front height lamps
K5	Position lamp relay	F17	NANO key switch fuse	F30	Tractor ABS15 electric fuse	E221, E222	Left and right rear height lamps
K13	15 power relay	F18	Position lamp relay fuse	F31	Trailer ABS15 electric fuse	E225, E226	Left and right front marker lamps
F3	Interior lamp, VDR, MP5 OBD fuse	F19	Right position lamp fuse	F32	Vehicle-mounted monitoring equipment/GL 15 electric fuse	E227, E228	Left and right rear marker lamps
F5	Rear module fuse of vehicle	F21	Left position lamp fuse	F33	NANO TCU 15 electric fuse		
F7	Instrument cluster assembly BBM fuse	F22	40A15 electric relay fuse	F40	Instrument cluster assembly 15 electric fuse		
F9	NANO fuse	F23	Left door-controlled switch fuse	F41	ECU SCR 15 electric fuse		
F39	ECAS, standby 15 power interface fuse	F24	Right door-controlled switch fuse	S101	Key switch		

G- Negative electrode of battery

A101 Electrical junction box, starting device under vehicle, key switch

This electrical schematic diagram shows the technical status of this model as of July 30, 2022. Subject to change without prior notice.

Mark	No. of pieces	File No.	Signature	Date

DSGN				
REWD				
CHKD				
STD.				
Process				
CTSG				
APPR				

Drawing Mark	Qty.	Scale
Trial	Small	Finished
page(s) in total	Page	

China National heavy Duty Truck Group Co., Ltd.

Electrical Schematic Diagram of SITRAK-C7H Vehicles (Nano+TFT) (Ver. 2022-01)-3

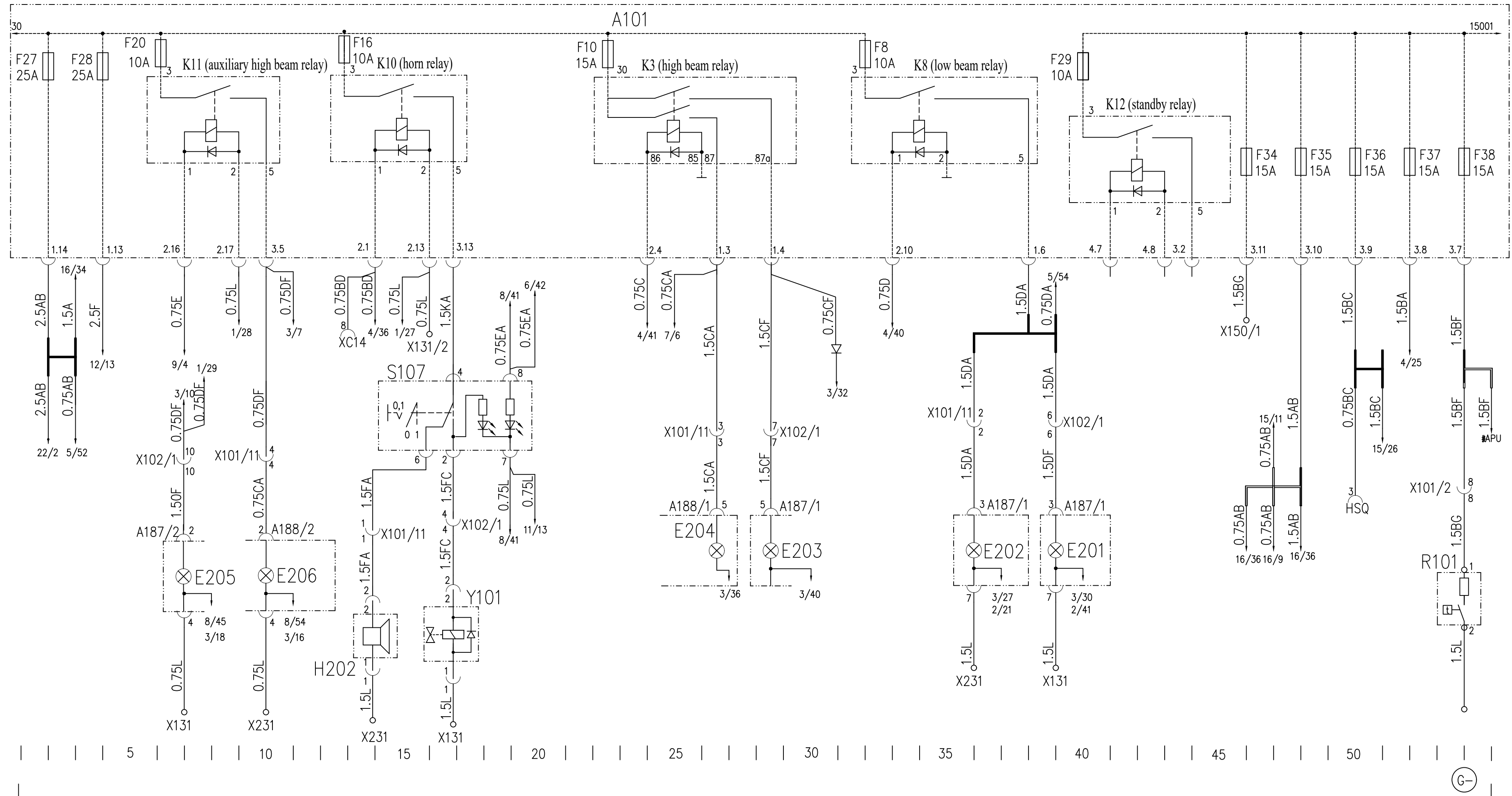

A101	Electrical junction box	F16	Horn relay fuse	F38	Air dryer fuse	E201, E202	Left and right low beams
K3	High beam relay	F20	Auxiliary high beam relay fuse	F35	VCU fuse	E203, E204	Left and right high beams
K8	Low beam relay	F27	Instrument cluster assembly ECAS VCU fuse	S107	Horn change-over switch	E205, E206	Left and right auxiliary high beams
K10	Horn relay	F28	Air conditioner power fuse	H202	Electric horn	X231	Bonding point of right wire box
K11	Auxiliary high beam relay	F29	Standby fuse	Y101	Pneumatic horn solenoid valve	X131	Bonding point of left wire box
K12	Standby relay	F34	15 electric splitter, VCU fuse	R101	Air drier	X131/1	Ground wire splitter
F8	Standby relay fuse	F36	15 electric fuse for retarder, etc.	A187	Left combination headlamp assembly		
F10	High beam relay fuse	F37	Electric fuse for wiper switch	A188	Right combination headlamp assembly		

Negative electrode of battery

Electrical junction box, electric horn, pneumatic horn, left and right high beams, left and right low beams, air dryer

This electrical schematic diagram shows the technical status of this model as of July 30, 2022. Subject to change without prior notice.

Mark	No. of Pieces	File No.	Signature	Date

DSGN				
REWD				
CHKD				
STD.				
Process				
CTSG				
APPR				

Drawing Mark	Qty.	Scale
Trial	Small	Finished
page(s) in total	Page	

China National heavy Duty Truck Group Co., Ltd.

Electrical Schematic Diagram of SITRAK-C7H Vehicles (Nano+TFT) (Ver. 2022-01)-5

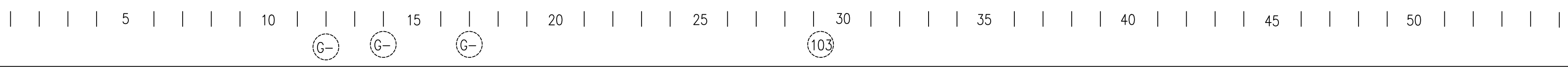
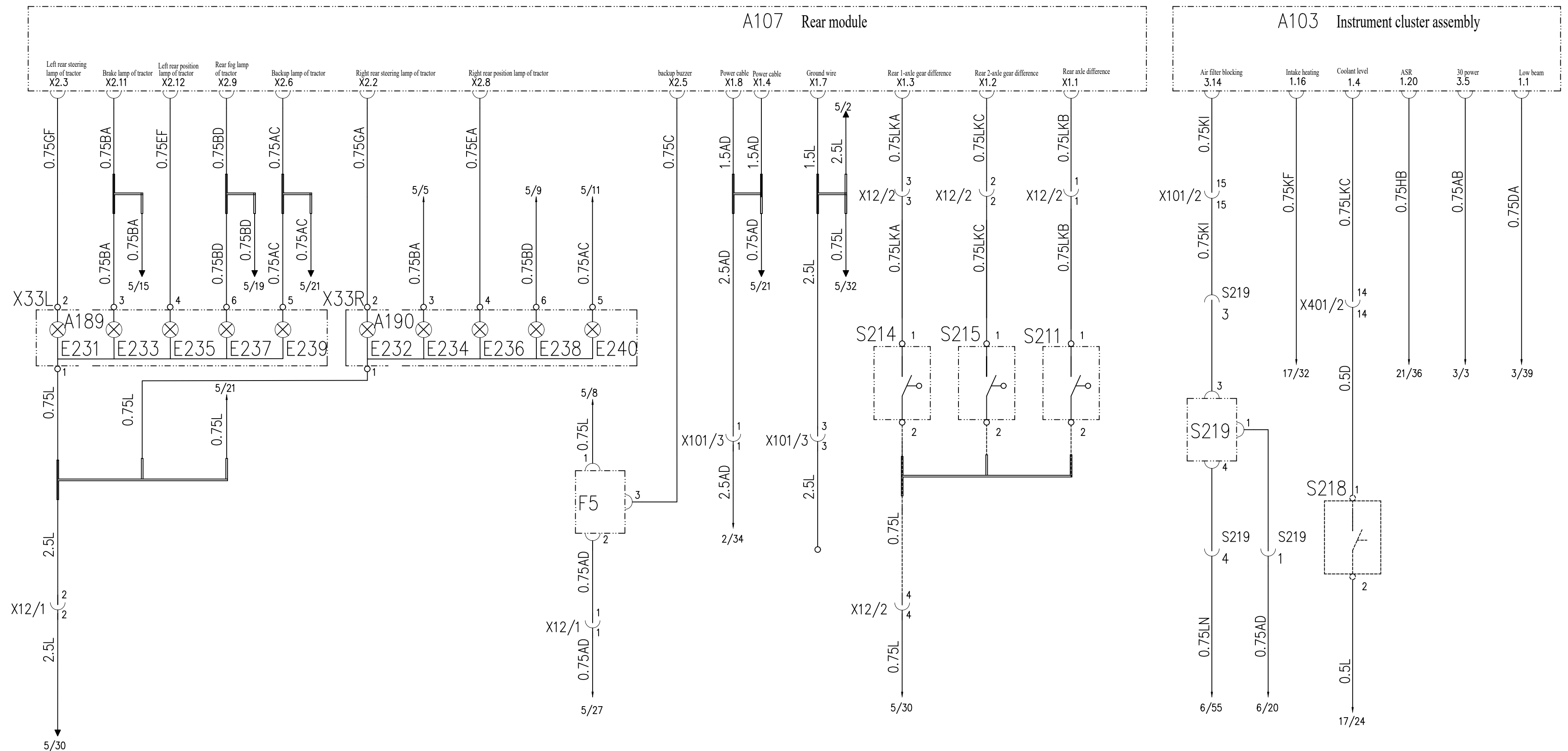

A103	Instrument cluster assembly	S215	Rear 2-axle inter-wheel differential lock signal switch	S218	Coolant level switch
A107	Rear module	E231/E232	Left and right rear steering lamps of tractor	S219	Air filter blocking alarm switch
A189	Left combination rear tail lamp	E233/E234	Left and right brake lamps of tractor	F5	Steering backup buzzer
A190	Right combination rear tail lamp	E235/E236	Left and right rear position lamps of tractor		
S211	Differential lock signal switch between rear axle shafts	E237/E238	Left and right rear fog lamps of tractor		
S214	Rear 1-axle inter-wheel differential lock signal switch	E239/E240	Left and right backup lamps of tractor		

Negative crimping point of battery

Rear module, instrument cluster assembly

This electrical schematic diagram shows the technical status of this model as of July 30, 2022.
Subject to change without prior notice.

Mark	No. of pieces	File No.	Signature	Date

DSGN			
REWD			
CHKD			
STD.			
Process			
CTSG			
APPR			

Drawing Mark	Qty.	Scale
Trial	Small	Finished
page(s) in total	Page	

China National heavy Duty Truck Group Co., Ltd.

Electrical Schematic Diagram of SITRAK-C7H Vehicles (Nano+TFT) (Ver. 2022-01)-6

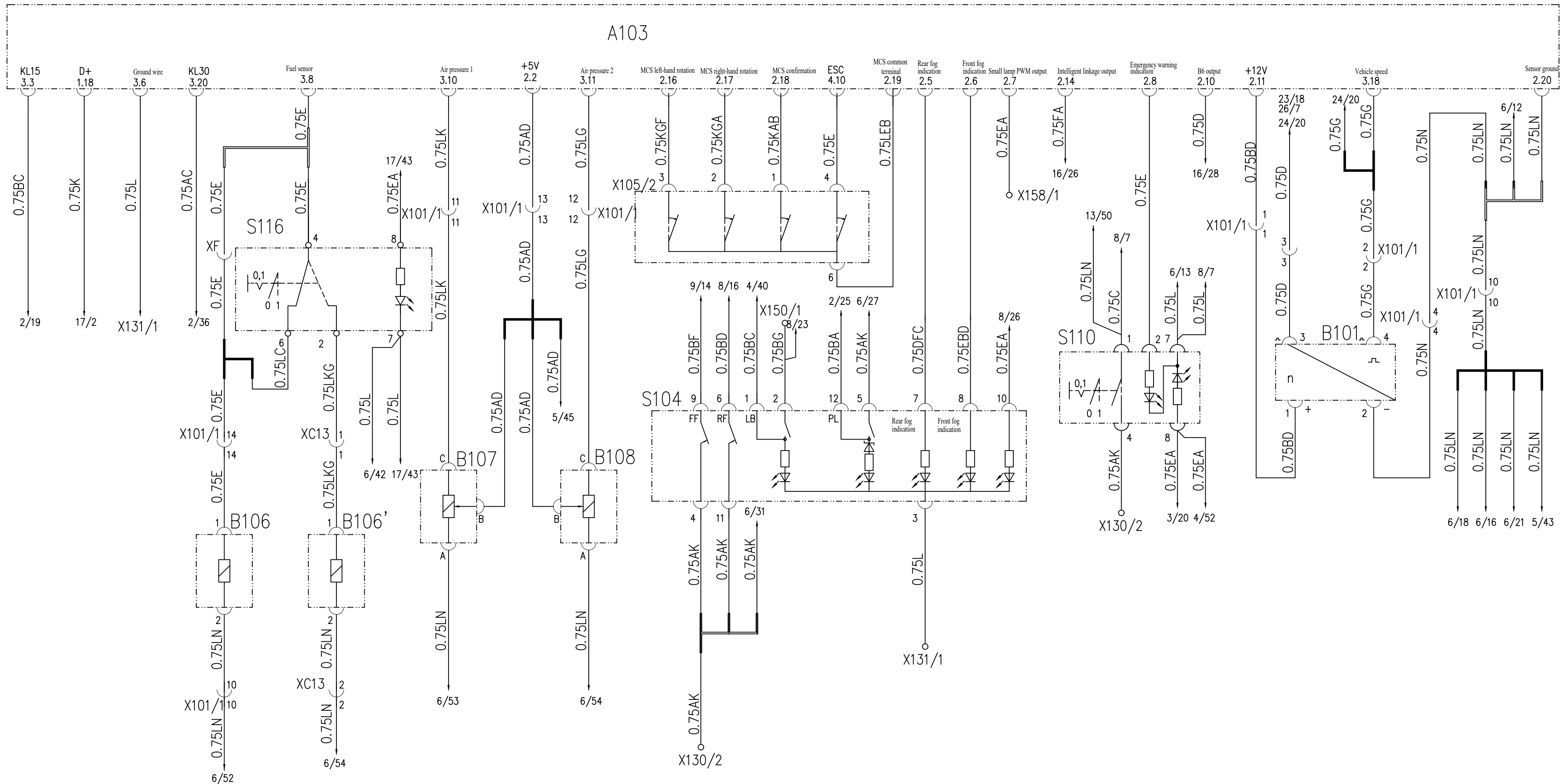

A103	Instrument cluster assembly	B106	Fuel sensor		
S104	Light knob switch	B107	Air pressure sensor of brake circuit 1		
S110	Emergency alarm switch	B108	Air pressure sensor of brake circuit 2		
S116	Change-over switch for main and auxiliary fuel tanks	X130/2	30 power splitter of rocker switch		
X105/2	Menu knob	X158/1	Small lamp lighting power splitter		
B101	Vehicle speed sensor	X131/1	Bonding point of left cowl wire box		

Instrument cluster assembly, air pressure sensor, vehicle speed sensor, light knob switch, emergency alarm switch

This electrical schematic diagram shows the technical status of this model as of July 30, 2022.
Subject to change without prior notice.

Mark	No. of Pieces	File No.	Signature	Date

DSGN				
REWD				
CHKD				
STD.				
Process				
CTSG				
APPR				

Drawing Mark	Qty.	Scale
Trial	Small	Finished
page(s) in total		Page

China National heavy Duty Truck Group Co., Ltd.

Electrical Schematic Diagram of SITRAK-C7H Vehicles (Nano+TFT) (Ver. 2022-01)-7

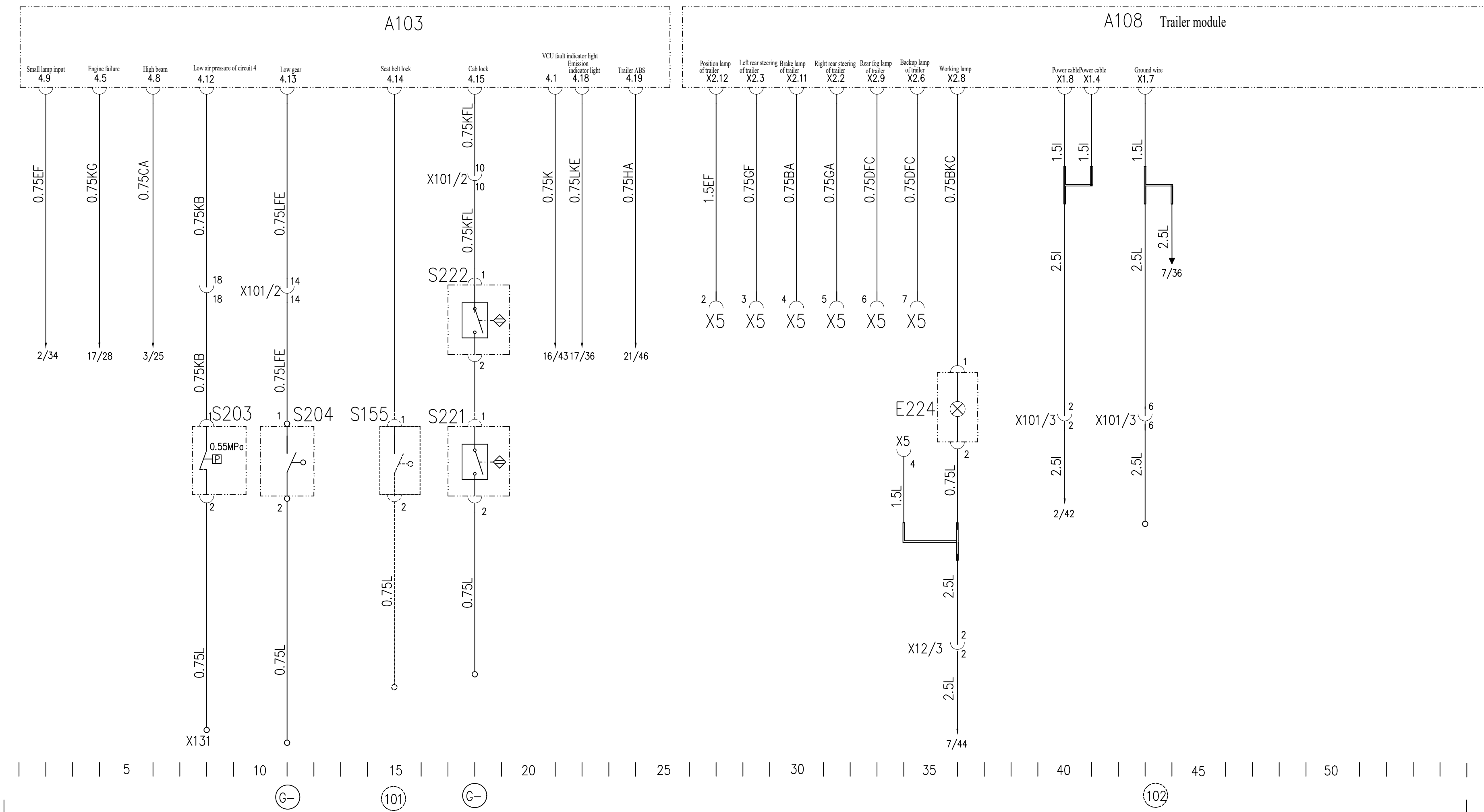

A103	Instrument cluster assembly	S222	Right cab lock signal switch		
A108	Trailer module	S221	Left cab lock signal switch		
S155	Lock signal switch of seat belt	E224	Working lamp		
S203	Signal switch of brake circuit 4	X131	Bonding point of left wire box		
S204	Low gear signal switch of transmission	X5	Trailer socket		

G- Negative electrode of battery
 Instrument cluster assembly, signal switch of brake circuit 4, low gear signal switch, seat belt/cab lock signal switch, trailer module

This electrical schematic diagram shows the technical status of this model as of July 30, 2022.
 Subject to change without prior notice.

No. of Mark	File No.	Signature	Date

DSGN			
REWD			
CHKD			
STD.			
Process			
CTSG			
APPR			

Drawing Mark	Qty.	Scale
Trial	Small	Finished
page(s) in total		Page

China National heavy Duty Truck Group Co., Ltd.

Electrical Schematic Diagram of SITRAK-C7H Vehicles (Nano+TFT) (Ver. 2022-01)-8

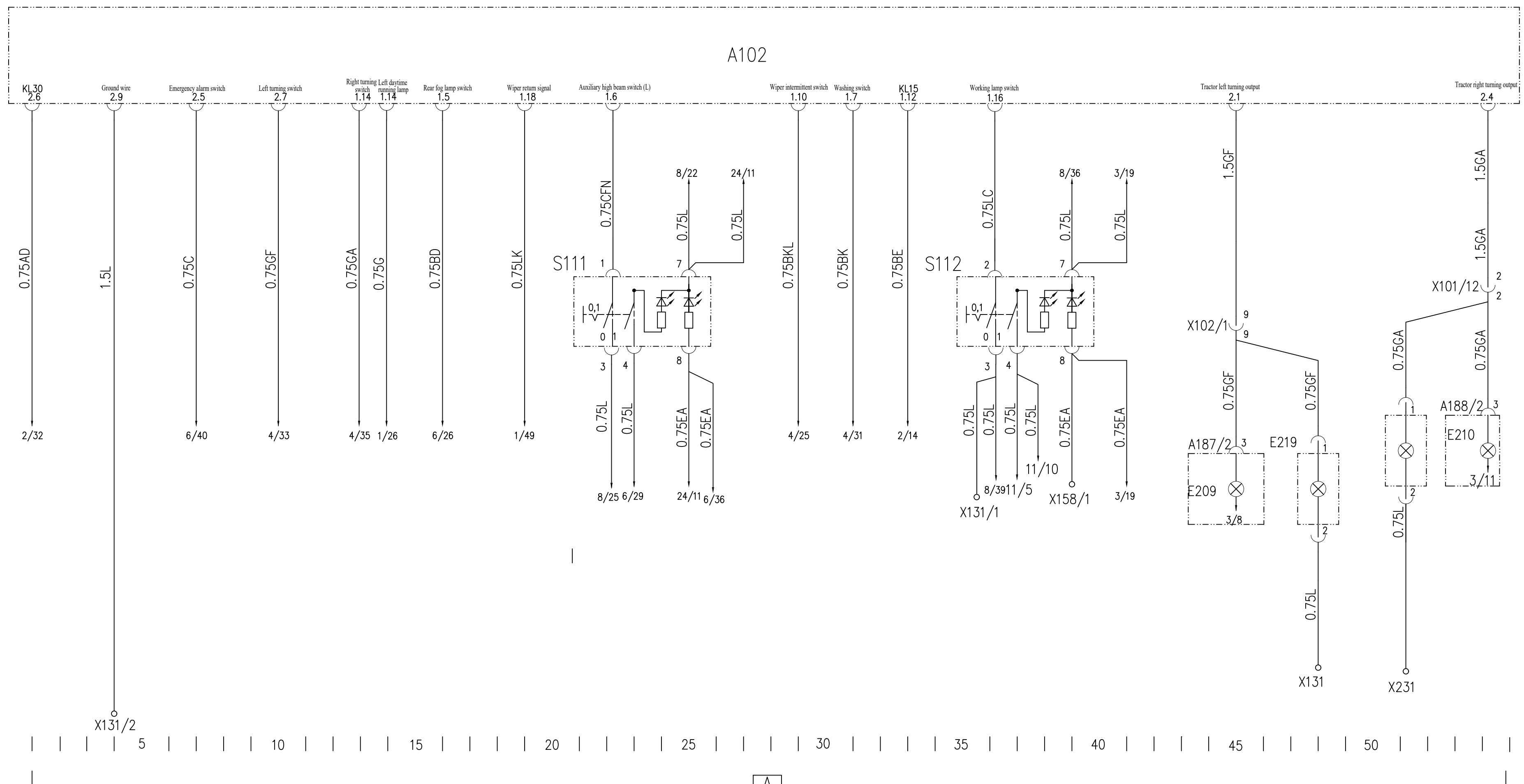

A102	NANO controller	E209	Left front turn light		
S111	Auxiliary high beam switch	E210	Right front turn light		
S112	Working lamp switch	E219	Left steering lamp		
A187	Left headlight assembly	E220	Right steering lamp		
A188	Right headlight assembly				

Nano controller, left/right steering lamp

This electrical schematic diagram shows the technical status of this model as of July 30, 2022. Subject to change without prior notice.

Mark	No. of Pieces	File No.	Signature	Date

DSGN				
REWD				
CHKD				
STD.				
Process				
CTS				
APPR				

Drawing Mark			Qty.	Scale
Trial	Small	Finished		
page(s) in total			Page	
China National heavy Duty Truck Group Co., Ltd.				

Electrical Schematic Diagram of SITRAK-C7H Vehicles (Nano+TFT) (Ver. 2022-01)-9

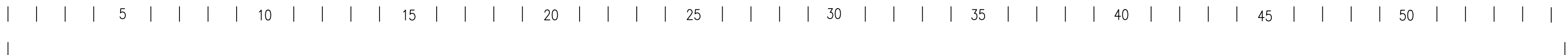
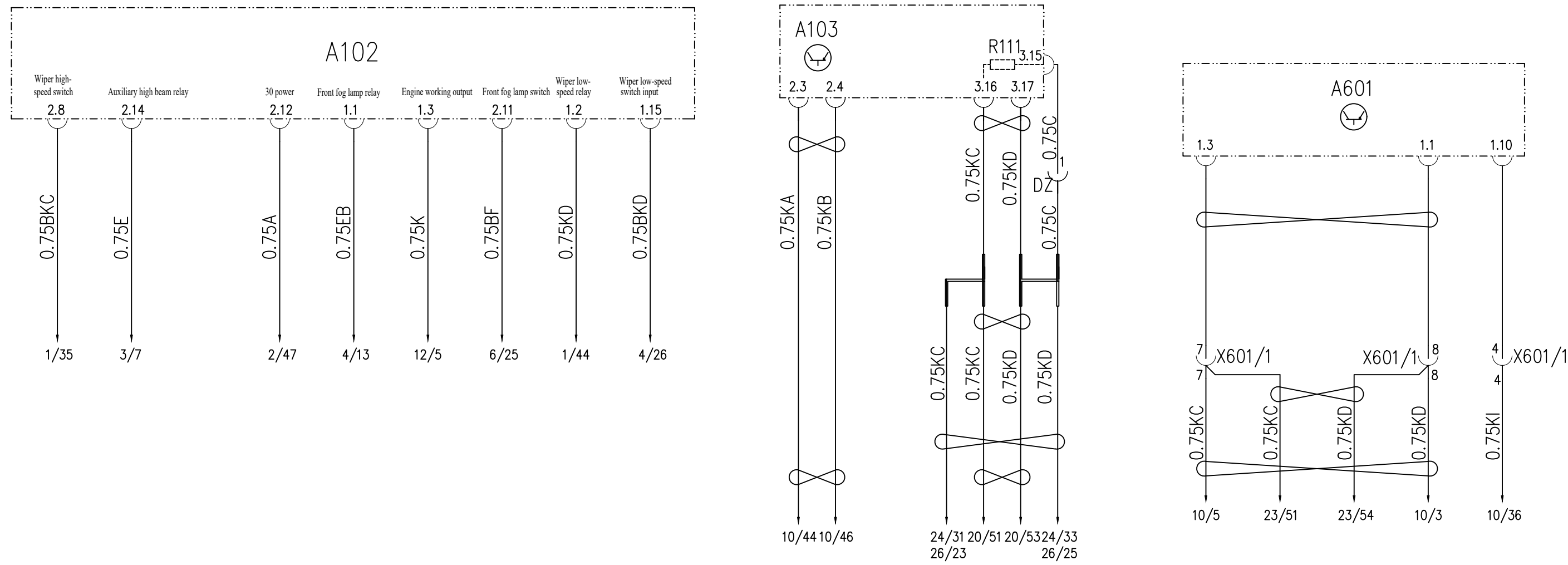

A102	NANO controller				
A103	Instrument cluster assembly				
A601	ABS controller				

(101) Driver-side bonding point in cab

NANO controller, vehicle CAN

This electrical schematic diagram shows the technical status of this model as of July 30, 2022. Subject to change without prior notice.

No. of Pages	File No.	Signature	Date

DSGN				
REWD				
CHKD				
STD.				
Process				
CTSG				
APPR				

Drawing Mark	Qty.	Scale
Trial	Small	Finished
page(s) in total	Page	

China National heavy Duty Truck Group Co., Ltd.

Electrical Schematic Diagram of SITRAK-C7H Vehicles (Nano+TFT) (Ver. 2022-01)-10

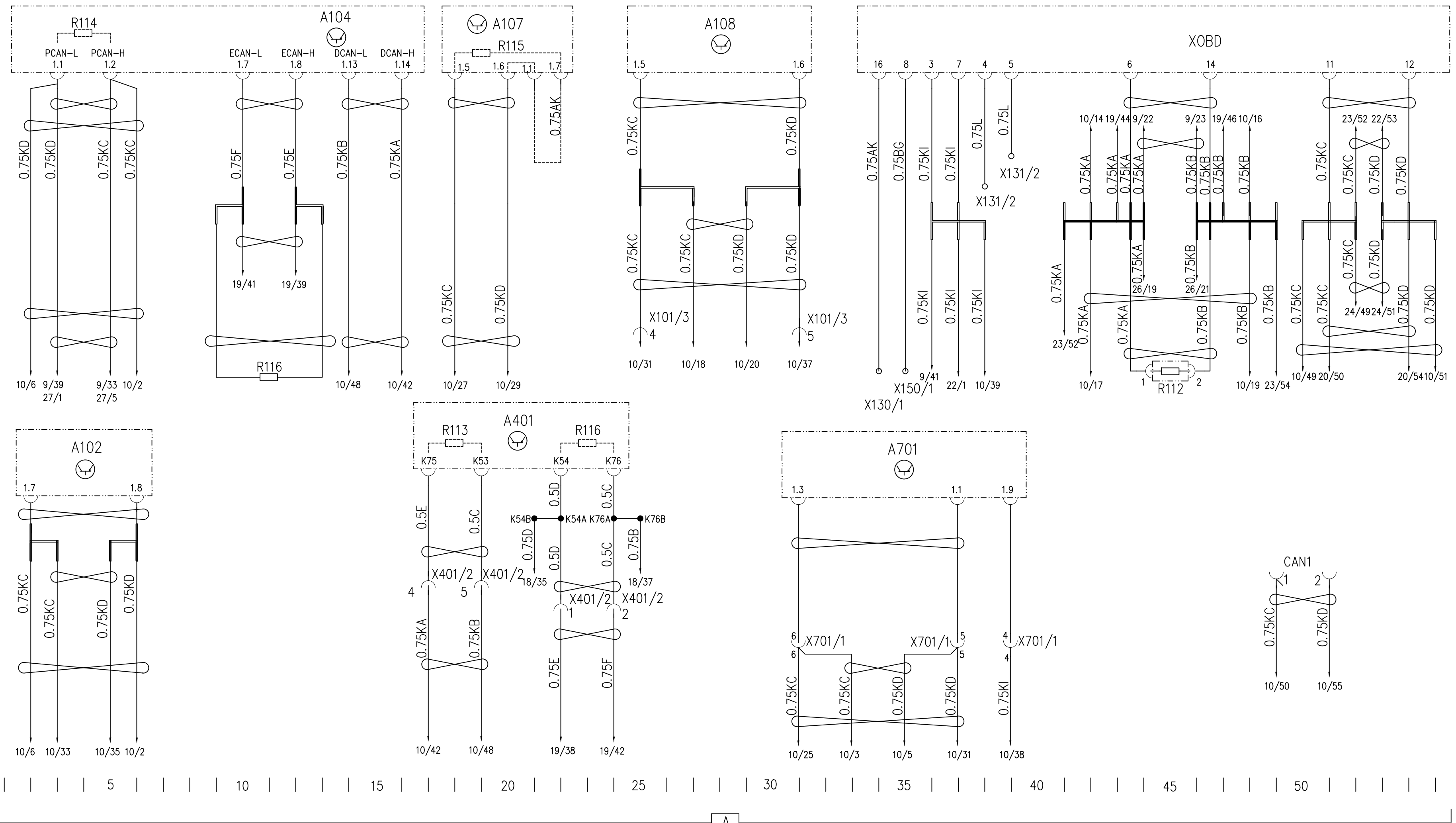

A102	NANO controller	A401	Engine controller	R111	Resistor of 120 ohm	R115	Resistor of 120 ohm
A104	Vehicle control unit VCU	A701	ECAS controller	R112	Resistor of 120 ohm	R116	Resistor of 120 ohm
A107	Rear module of vehicle	XOBD	Diagnostic interface	R113	Resistor of 120 ohm		
A108	Trailer module			R114	Resistor of 120 ohm		

(101) Driver-side bonding point in cab

Vehicle CAN

This electrical schematic diagram shows the technical status of this model as of July 30, 2022.
Subject to change without prior notice.

Mark	No. of Pieces	File No.	Signature	Date

DSGN			
REWD			
CHKD			
STD.			
Process			
CTSG			
APPR			

Drawing Mark	Qty.	Scale
Trial	Small	Finished
page(s) in total	Page	

China National heavy Duty Truck Group Co., Ltd.

Electrical Schematic Diagram of SITRAK-C7H Vehicles (Nano+TFT) (Ver. 2022-01)-13

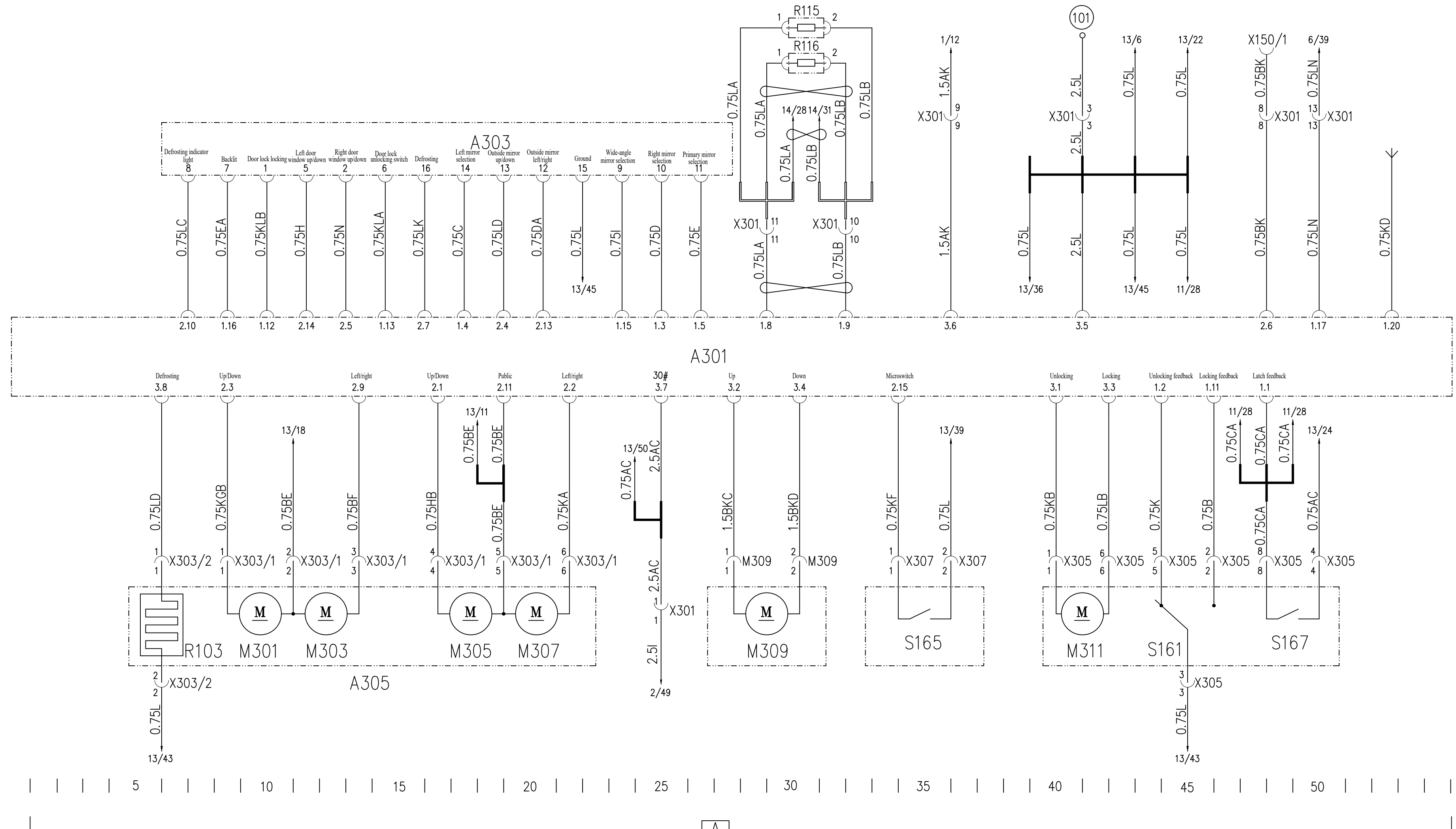

A301	Door control module at driver's side	M303	Left/right moving motor of wide-angle mirror at driver's side
A303	Door control operation panel at driver's side	M305	Up/down moving motor of outside mirror at driver's side
A305	Outside mirror at driver's side	M307	Left/right moving motor of outside mirror at driver's side
S161	Unlock/lock switch of operation panel at driver's side	M309	Up/down motor of door window at driver's side
S165	Key locking signal switch at driver's side	M311	Door lock motor at driver's side
S167	Latch feedback switch at driver's side	R103	Defroster of outside mirror at driver's side
M301	Up/down moving motor of wide-angle mirror at driver's side		

(101) Driver-side bonding point in cab

Peripheral circuit of door control module at driver's side

This electrical schematic diagram shows the technical status of this model as of July 30, 2022.
Subject to change without prior notice.

Mark	No. of Pieces	File No.	Signature	Date

DSGN				
REWD				
CHKD				
STD.				
Process				
CTSG				
APPR				

Drawing Mark	Qty.	Scale
Trial	Small	Finished
Page(s) in total	Page	

China National heavy Duty Truck Group Co., Ltd.

Electrical Schematic Diagram of SITRAK-C7H Vehicles (Nano+TFT) (Ver. 2022-01)-15

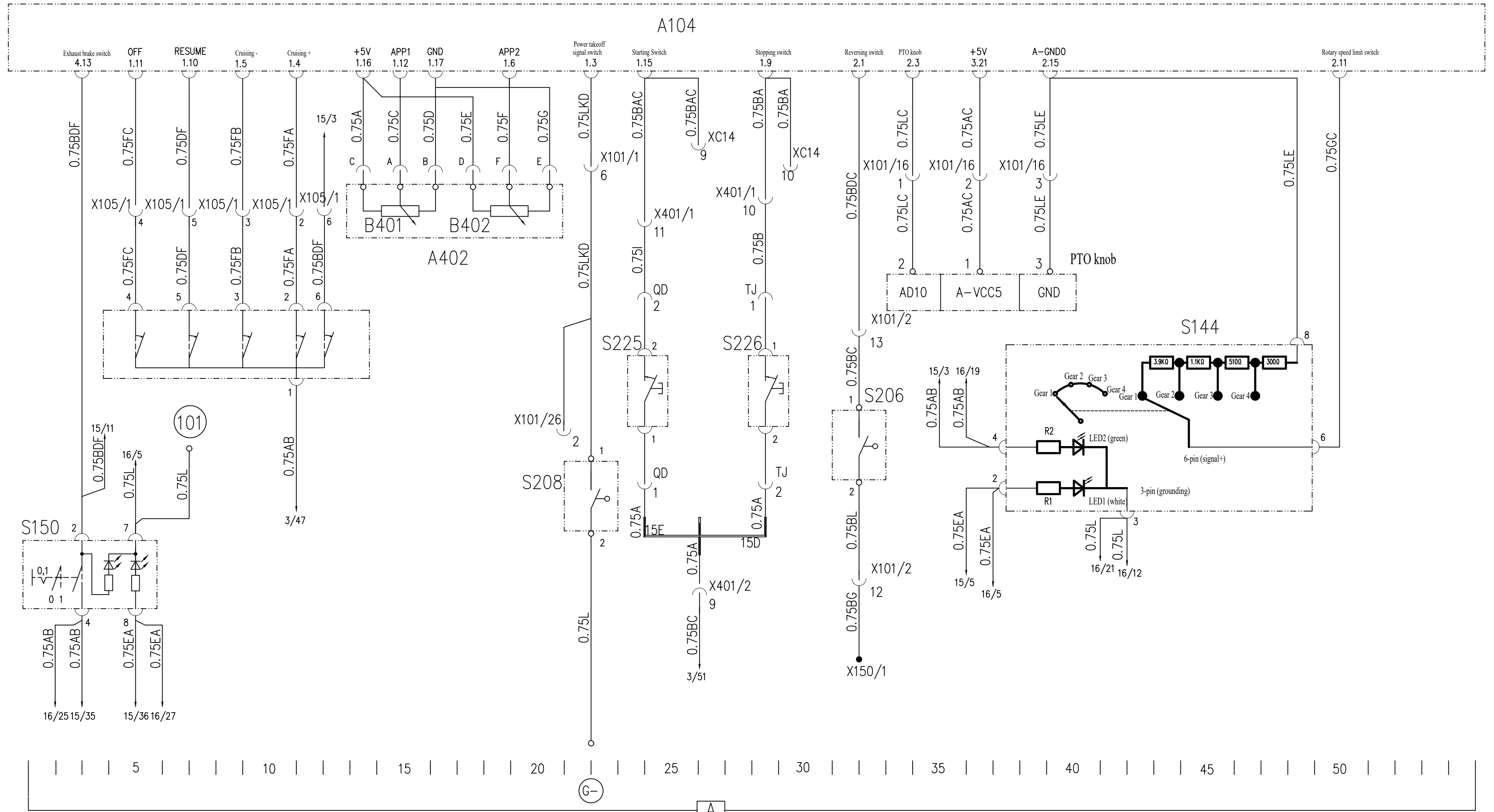

A104	Vehicle control module VCU	S225	Starting button under vehicle
A402	Electronic accelerator pedal	S226	Stopping button under vehicle
S144	Rotary speed mode switch of engine	S208	Power takeoff signal switch
S150	Exhaust brake switch	S206	Transmission reverse signal switch (non AMT)

(101) Driver-side bonding point

(G-) Negative crimping point of battery

Peripheral circuit of vehicle control module VCU

This electrical schematic diagram shows the technical status of this model as of July 30, 2022. Subject to change without prior notice.

Mark	No. of Pieces	File No.	Signature	Date

DSGN			
REWD			
CHKD			
STD.			
Process			
CTSG			
APPR			

Drawing Mark	Qty.	Scale
Trial	Small	Finished
page(s) in total	Page	

China National heavy Duty Truck Group Co., Ltd.

Electrical Schematic Diagram of SITRAK-C7H Vehicles (Nano+TFT) (Ver. 2022-01)-16

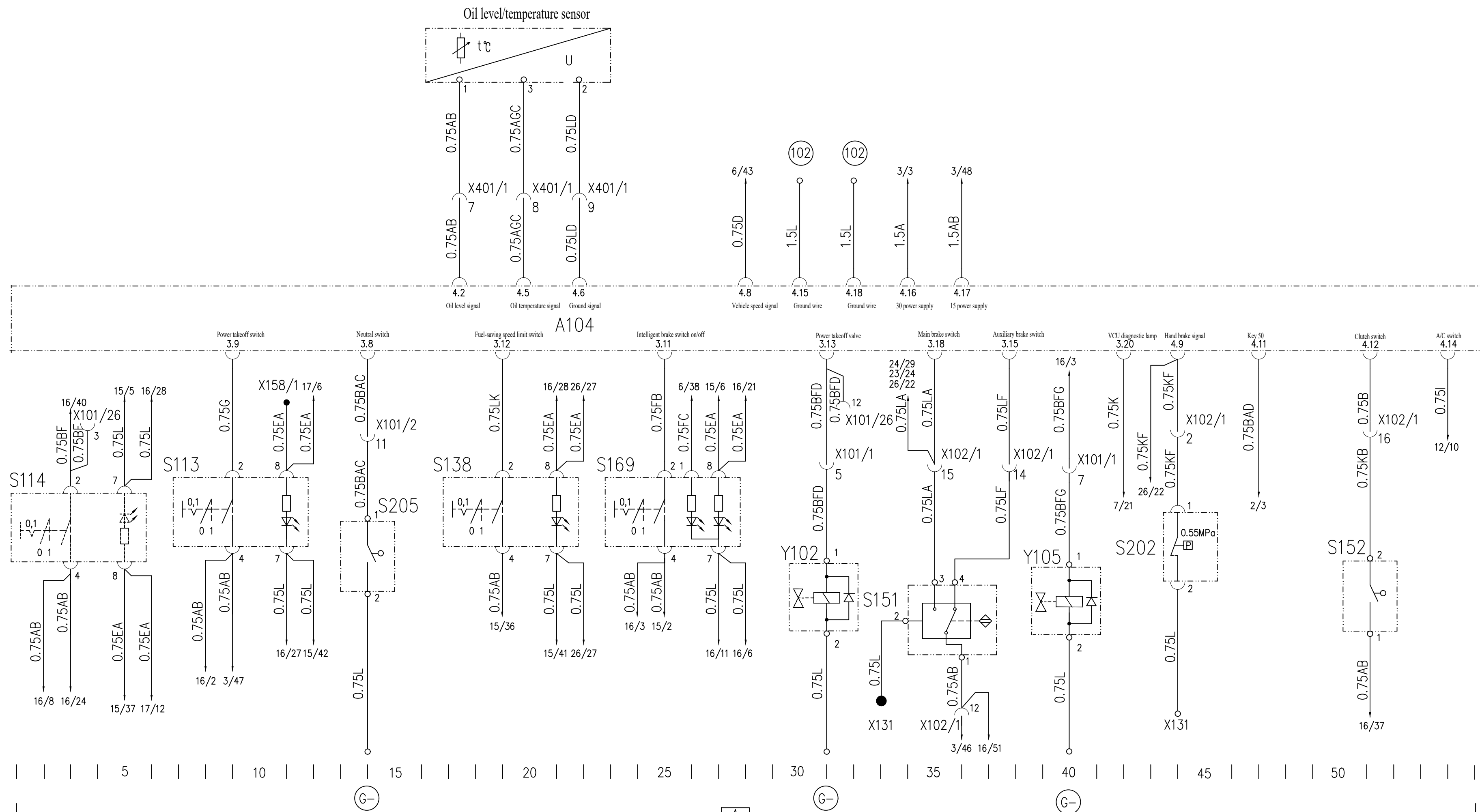

A104	Vehicle control unit VCU	S205	Transmission neutral switch (non-AMT)	S169	Intelligent brake switch		
Y102	Power takeoff solenoid valve	S113	Power takeoff rocker switch				
Y105	Power takeoff neutral solenoid valve	S114	Power takeoff neutral rocker switch				
S202	Hand brake signal switch	S138	Fuel-saving speed limit switch				
S152	Clutch switch	S151	Brake lamp switch				

- (101) Driver-side bonding point in cab
- (G-) Negative bonding point of battery

This electrical schematic diagram shows the technical status of this model as of July 30, 2022. Subject to change without prior notice.

Peripheral circuit of vehicle control unit VCU

Mark	No. of Pieces	File No.	Signature	Date

DSGN				
REWD				
CHKD				
STD.				
Process				
CTSG				
APPR				

Drawing Mark	Qty.	Scale	
Trial	Small	Finished	
page(s) in total	Page		

China National heavy Duty Truck Group Co., Ltd.

Electrical Schematic Diagram of SITRAK-C7H Vehicles (Nano+TFT) (Ver. 2022-01)-17

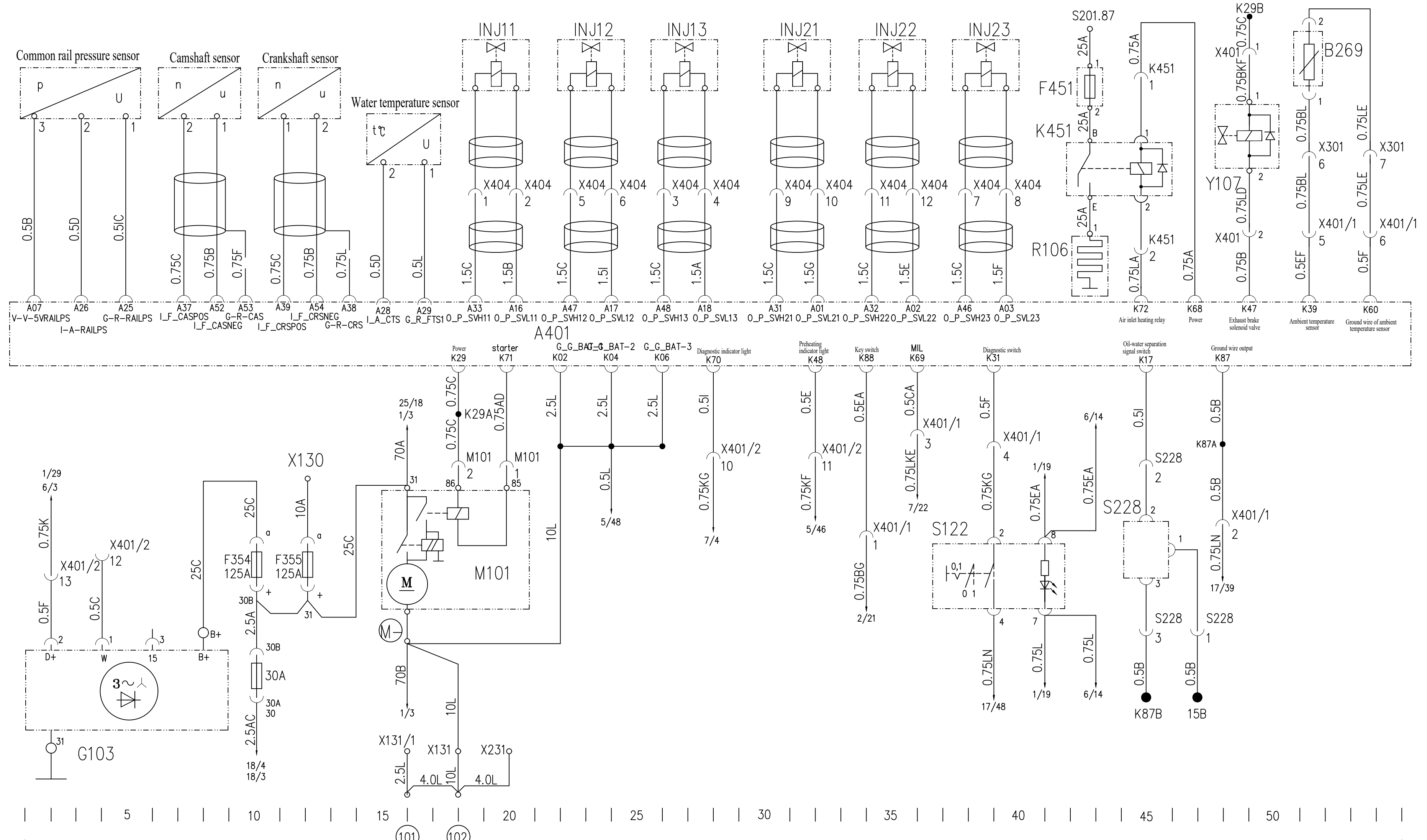

A401	Engine ECU	K452	Fuel heating relay	INJ13	#3 fuel injector
F451	Preheating fuse	B269	Ambient temperature sensor	INJ21	#4 fuel injector
M101	Starter	K451	Preheating relay	INJ22	#5 fuel injector
S122	ECU diagnostic switch	R106	Preheater	INJ23	#6 fuel injector
S228	Oil-water separation sensor	INJ11	#1 fuel injector	Y107	Exhaust brake solenoid valve
G103	Alternator	INJ12	#2 fuel injector		

- 101 Driver-side bonding point in cab
- 102 Bonding point at co-driver's side in cab
- M- Bonding point of engine

This electrical schematic diagram shows the technical status of this model as of July 30, 2022.
Subject to change without prior notice.

Peripheral circuit of engine ECU

Mark	No. of Pieces	File No.	Signature	Date

DSGN				
REWD				
CHKD				
STD.				
Process				
CTS				
APPR				

Drawing Mark	Qty.	Scale
Trial	Small	Finished
page(s) in total		Page

China National heavy Duty Truck Group Co., Ltd.

Electrical Schematic Diagram of SITRAK-C7H Vehicles (Nano+TFT) (Ver. 2022-01)-18

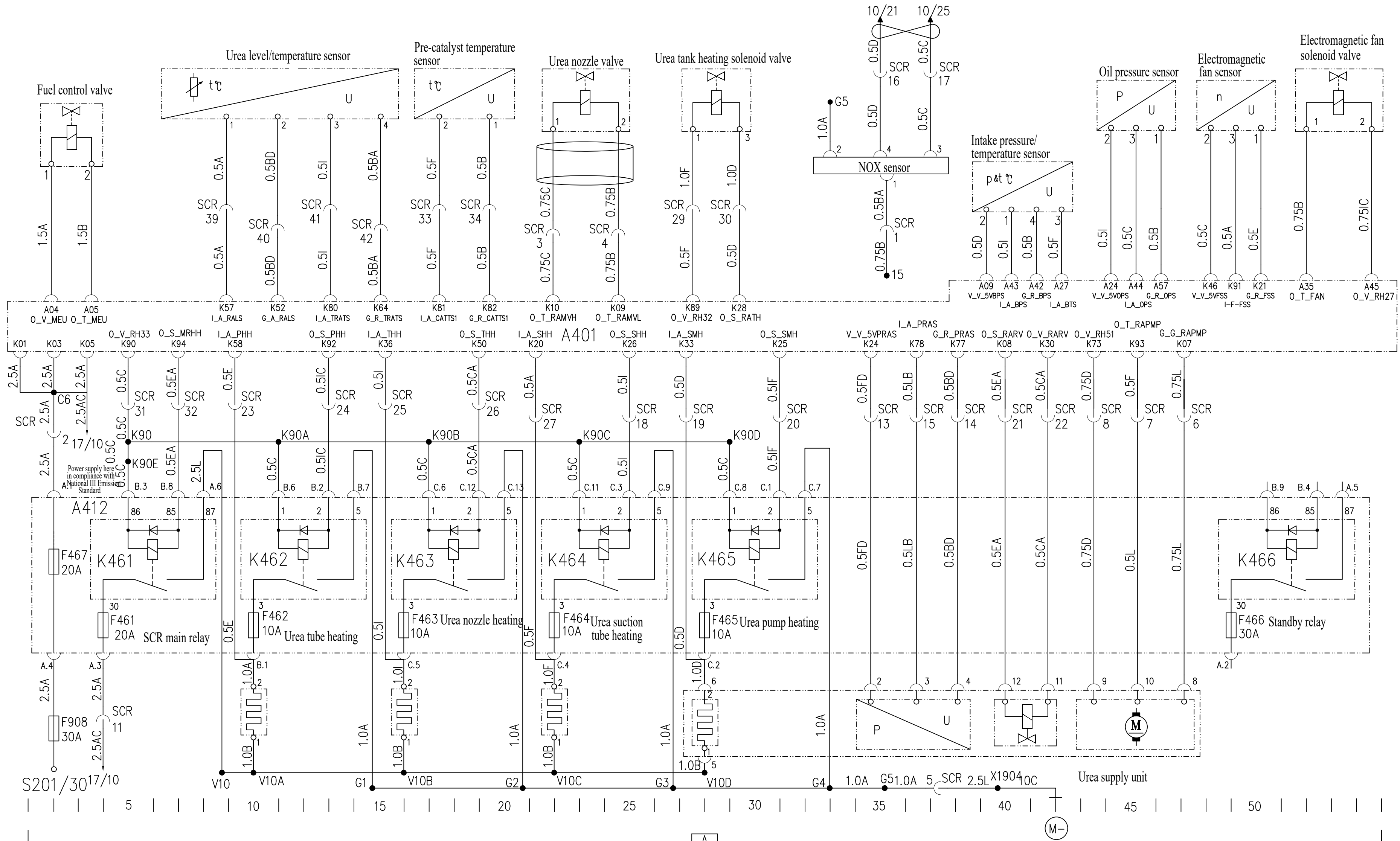

A401	Engine ECU	R106	Preheater	INJ23	#6 fuel injector	F466	Standby fuse	K465	Urea pump heating relay
F451	Preheating fuse	INJ11	#1 fuel injector	F461	SCR main relay fuse	F907	ECU-30 power fuse	K466	Standby relay
K451	Preheating relay	INJ12	#2 fuel injector	F462	Urea tube heating fuse	K461	SCR main relay	F908	Primary electric fuse
Y107	Exhaust brake solenoid valve	INJ13	#3 fuel injector	F463	Urea nozzle heating fuse	K462	Urea tube heating relay		
B269	Ambient temperature sensor	INJ21	#4 fuel injector	F464	Urea suction tube heating fuse	K463	Urea nozzle heating relay		
A412	Electrical junction box on chassis	INJ22	#5 fuel injector	F465	Urea pump heating fuse	K464	Urea suction tube heating relay		

(M-) Bonding point of engine

This electrical schematic diagram shows the technical status of this model as of July 30, 2022.
Subject to change without prior notice.

Peripheral circuit of engine ECU

Mark	No. of Pages	File No.	Signature	Date

DSGN				
REWD				
CHKD				
STD.				
Process				
CTSG				
APPR				

Drawing Mark	Qty.	Scale
Trial	Small	Finished
page(s) in total		Page

China National heavy Duty Truck Group Co., Ltd.

Electrical Schematic Diagram of SITRAK-C7H Vehicles (Nano+TFT) (Ver. 2022-01)-19

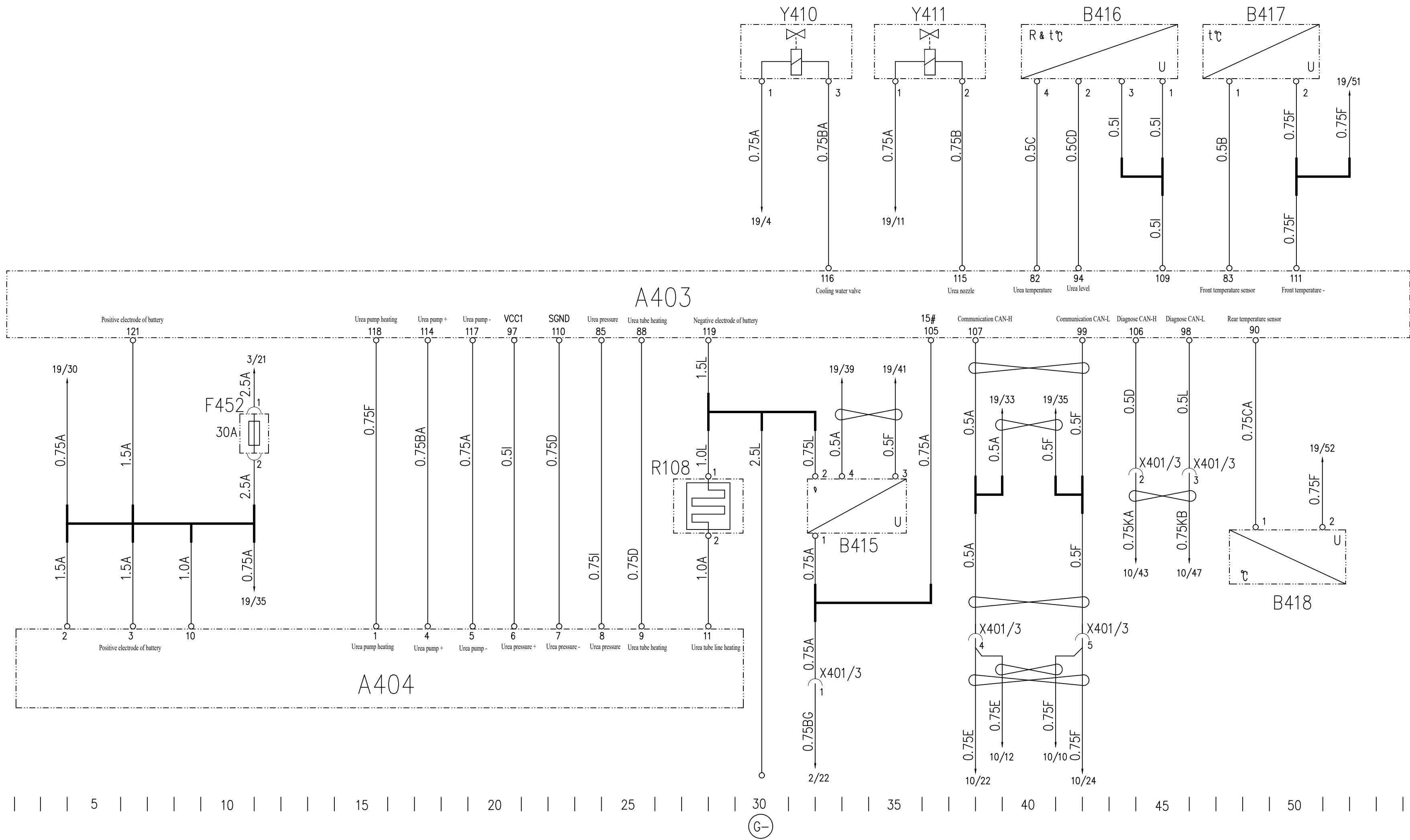

A403	SCR controller	F452	SCR fuse		
A404	Urea pump box	R108	Urea tube heater		
B415	NOX sensor	Y410	Cooling water valve		
B416	Urea temperature & level sensor	Y411	Urea nozzle		
B417	Front temperature sensor of SCR pack				
B418	Rear temperature sensor of SCR pack				

Negative crimping point of battery

This electrical schematic diagram shows the technical status of this model as of July 30, 2022.
Subject to change without prior notice.

Domestic SCR ECU peripheral circuit

Mark	No. of Pieces	File No.	Signature	Date

DSGN				
REWD				
CHKD				
STD.				
Process				
CTSG				
APPR				

Drawing Mark	Qty.	Scale
Trial	Small	Finished
page(s) in total	Page	

China National heavy Duty Truck Group Co., Ltd.

Electrical Schematic Diagram of SITRAK-C7H Vehicles (Nano+TFT) (Ver. 2022-01)-20

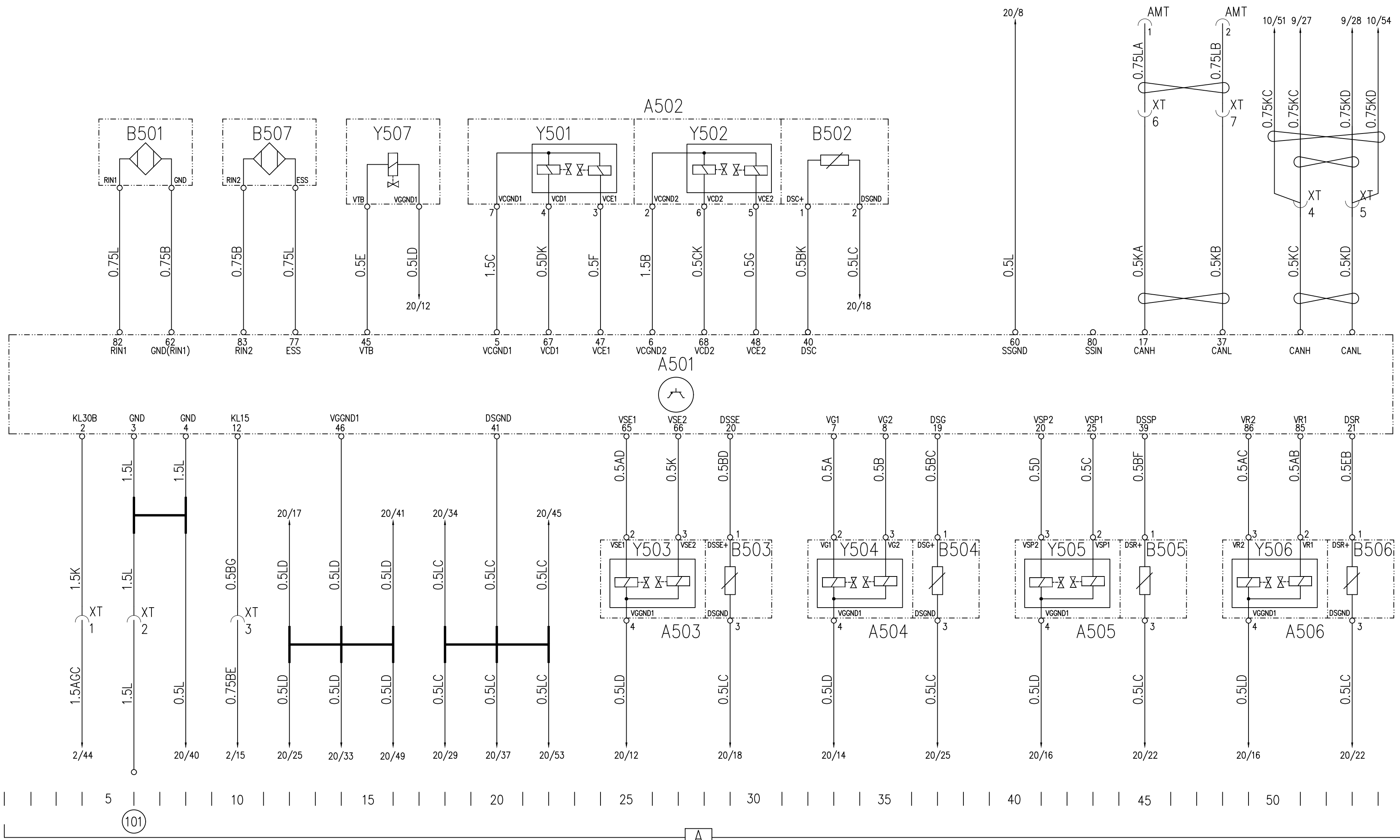

A501	AMT controller	B501	Input shaft sensor	B507	Output shaft sensor	Y506	Range gear solenoid valve
A502	Clutch actuator	B502	Clutch stroke sensor	Y501	Clutch actuator solenoid valve I	Y507	Transmission brake solenoid valve
A503	X actuator	B503	X actuator sensor	Y502	Clutch actuator solenoid valve II		
A504	Y actuator	B504	Y actuator sensor	Y503	X actuator solenoid valve		
A505	Differential gear cylinder	B505	Differential gear sensor	Y504	Y actuator solenoid valve		
A506	Range gear cylinder	B506	Range gear sensor	Y505	Differential gear solenoid valve		

(101) Bonding point at left cab side

Peripheral circuit of AMT controller

This electrical schematic diagram shows the technical status of this model as of July 30, 2022.
Subject to change without prior notice.

Mark	No. of Pieces	File No.	Signature	Date

DSGN				
REWD				
CHKD				
STD				
Process				
CTSG				
APPR				

Drawing Mark	Qty.	Scale
Trial	Small	Finished
page(s) in total	Page	

China National heavy Duty Truck Group Co., Ltd.

Electrical Schematic Diagram of SITRAK-C7H Vehicles (Nano+TFT) (Ver. 2022-01)-21

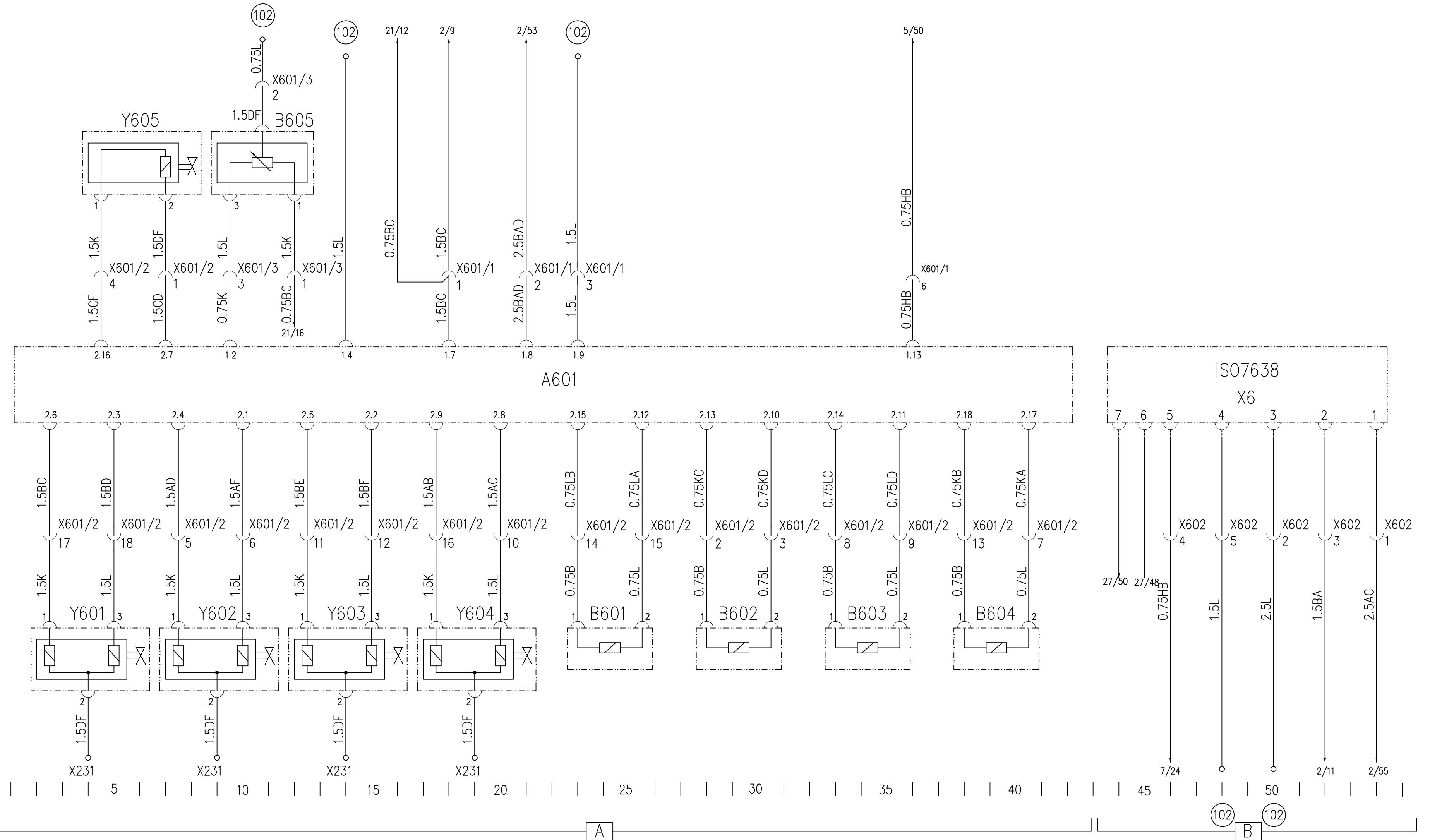

A601	ABS controller	S124	ABS diagnostic switch	Y604	Right rear wheel solenoid valve
B601	Left front wheel sensor	S127	ASR switch	Y605	ASR solenoid valve
B602	Right front wheel sensor	S133	ABS off-road switch	X6	ABS 7-hole trailer socket
B603	Left rear wheel sensor	Y601	Left front wheel solenoid valve		
B604	Right rear wheel sensor	Y602	Right front wheel solenoid valve		
B605	EBL sensor	Y603	Left rear wheel solenoid valve		

① Driver-side bonding point in cab

② Bonding point at co-driver's side in cab

A ABS E-VERSION BASIC 4S/4M WABCO

B Trailer ABS Socket

This electrical schematic diagram shows the technical status of this model as of July 30, 2022. Subject to change without prior notice.

Mark	No. of Pieces	File No.	Signature	Date

DSGN			
REWD			
CHKD			
STD.			
Process			
CTSG			
APPR			

Drawing Mark	Qty.	Scale
Trial	Small	Finished
pages(s) in total		Page
China National heavy Duty Truck Group Co., Ltd.		

Electrical Schematic Diagram of SITRAK-C7H Vehicles (Nano+TFT) (Ver. 2022-01)-22

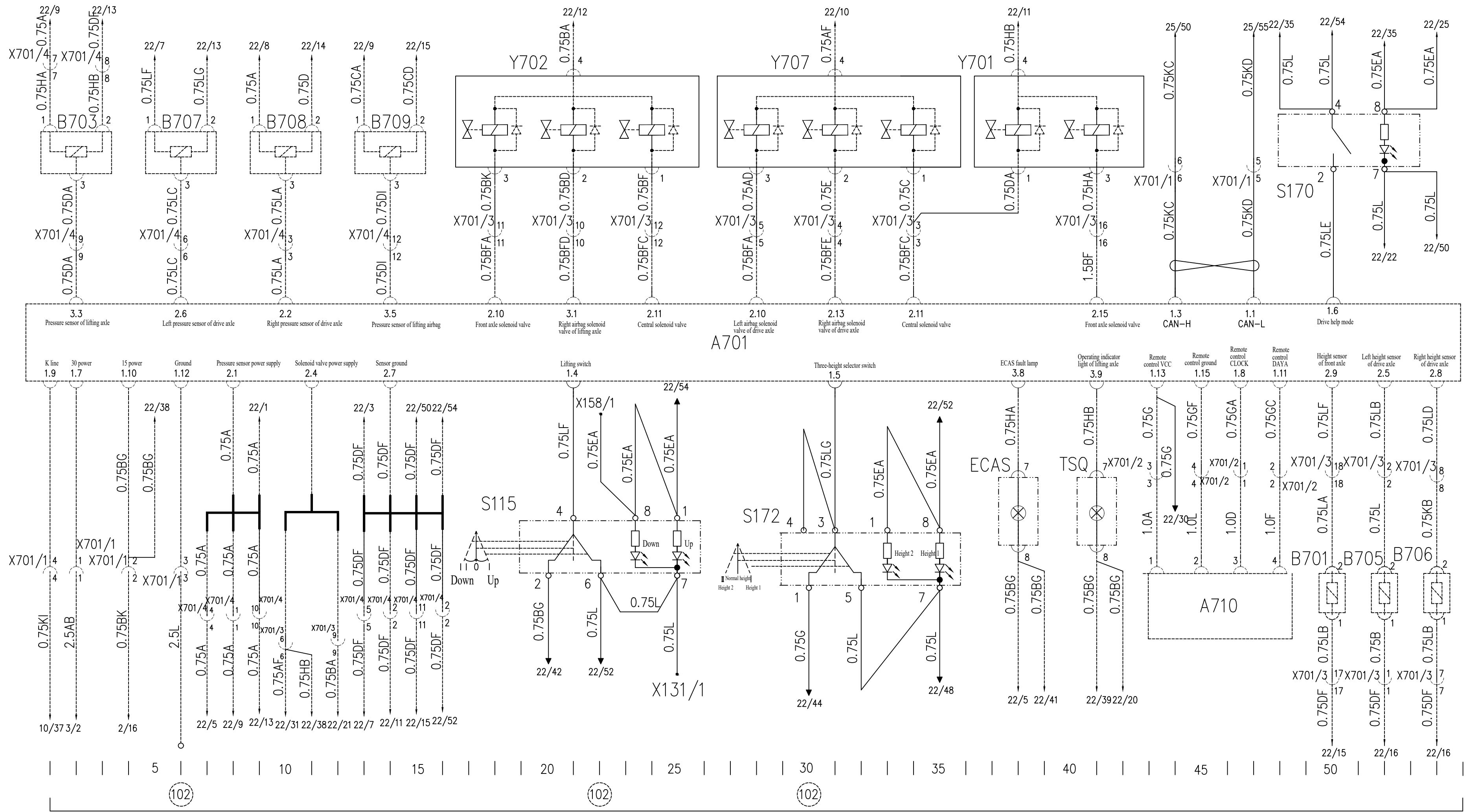

A701	ECAS controller	B701	Height sensor of front axle	B709	Main airbag pressure sensor of lifting axle
A710	ECAS remote control	B703	Pressure sensor of lifting shaft	Y701	Airbag solenoid valve of front axle
S115	Lifting switch of lifting shaft	B705	Left height & pressure sensor of drive axle	Y702	Main solenoid valve of lifting axle
S172	Three-height selector switch	B706	Right height & pressure sensor of drive axle	Y707	Solenoid valve of drive axle
S170	Drive help switch	B707	Left pressure sensor of drive axle	TSQ	Lifting axle indicator light
ECAS	ECAS fault lamp	B708	Right pressure sensor of drive axle		

ECAS BASIC 6x2 DA+LA

⑩ Bonding point at co-driver's side in cab

This electrical schematic diagram shows the technical status of this model as of July 30, 2022. Subject to change without prior notice.

Mark	No. of pieces	File No.	Signature	Date

DSGN			
REWD			
CHKD			
STD.			
Process			
CTSG			
APPR			

Drawing Mark	Qty.	Scale
Trial	Small	Finished
pages in total		Page
China National heavy Duty Truck Group Co., Ltd.		

Electrical Schematic Diagram of SITRAK-C7H Vehicles (Nano+TFT) (Ver. 2022-01)-24

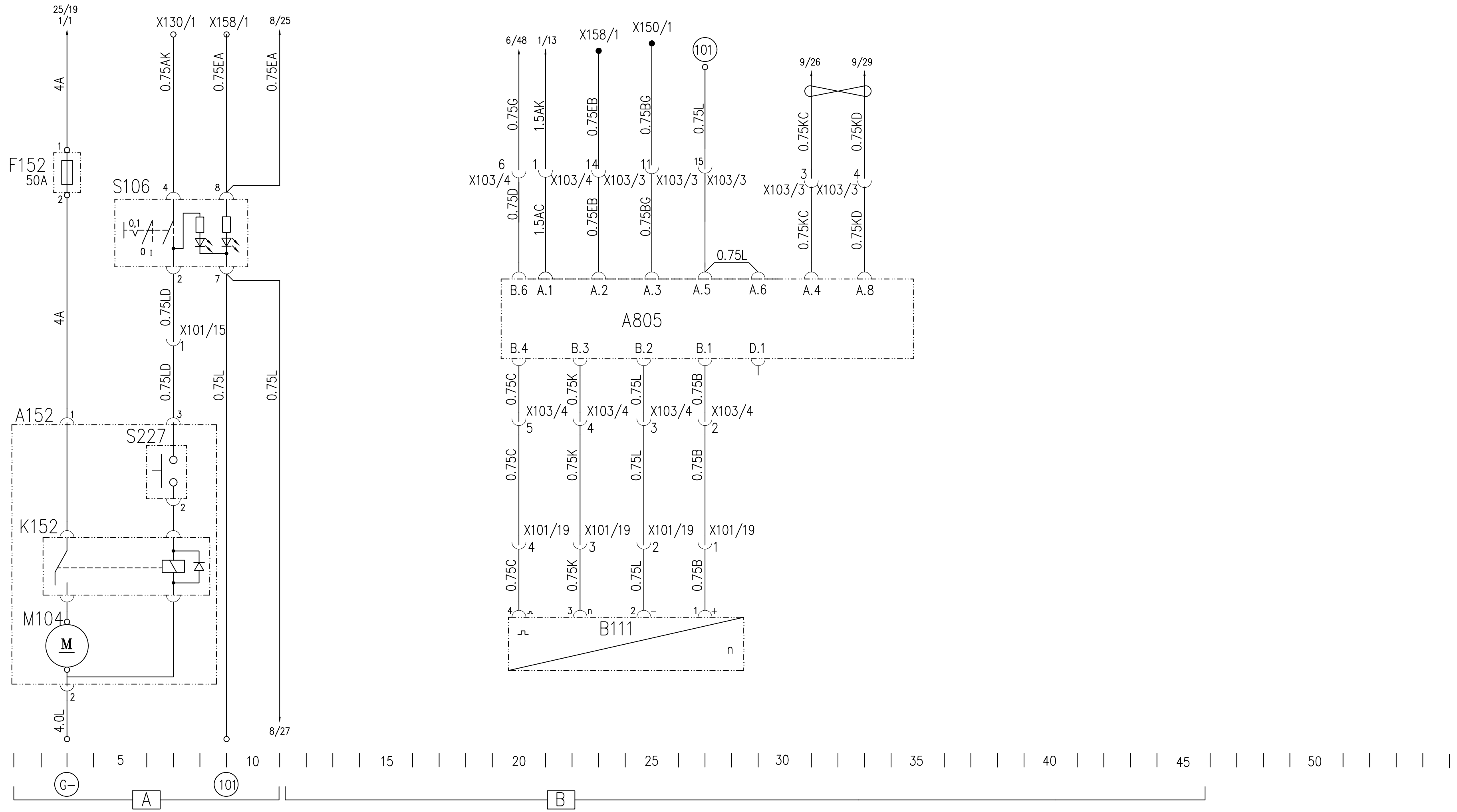

A152	Electric lifting device	S106	Electric lifting rocker switch		
A805	Tachograph (MTCO 1324)				
B111	KITAS vehicle speed sensor				
F152	Electric lifting fuse				
K152	Electric lifting relay				
M104	Electric lifting motor				
S227	Electric lifting switch				

- G- Negative crimping point of battery
- 101 Driver-side bonding point
- A Electric Lifting
- B Paper-Disc Tachograph (MTCO 1324)

This electrical schematic diagram shows the technical status of this model as of July 30, 2022. Subject to change without prior notice.

Mark	No. of Pieces	File No.	Signature	Date

DSGN			
REWD			
CHKD			
STD.			
Process			
CTSG			
APPR			

Drawing Mark	Qty.	Scale
Trial	Small	Finished
pages in total		Page
China National heavy Duty Truck Group Co., Ltd.		

Electrical Schematic Diagram of SITRAK-C7H Vehicles (Nano+TFT) (Ver. 2022-01)-25

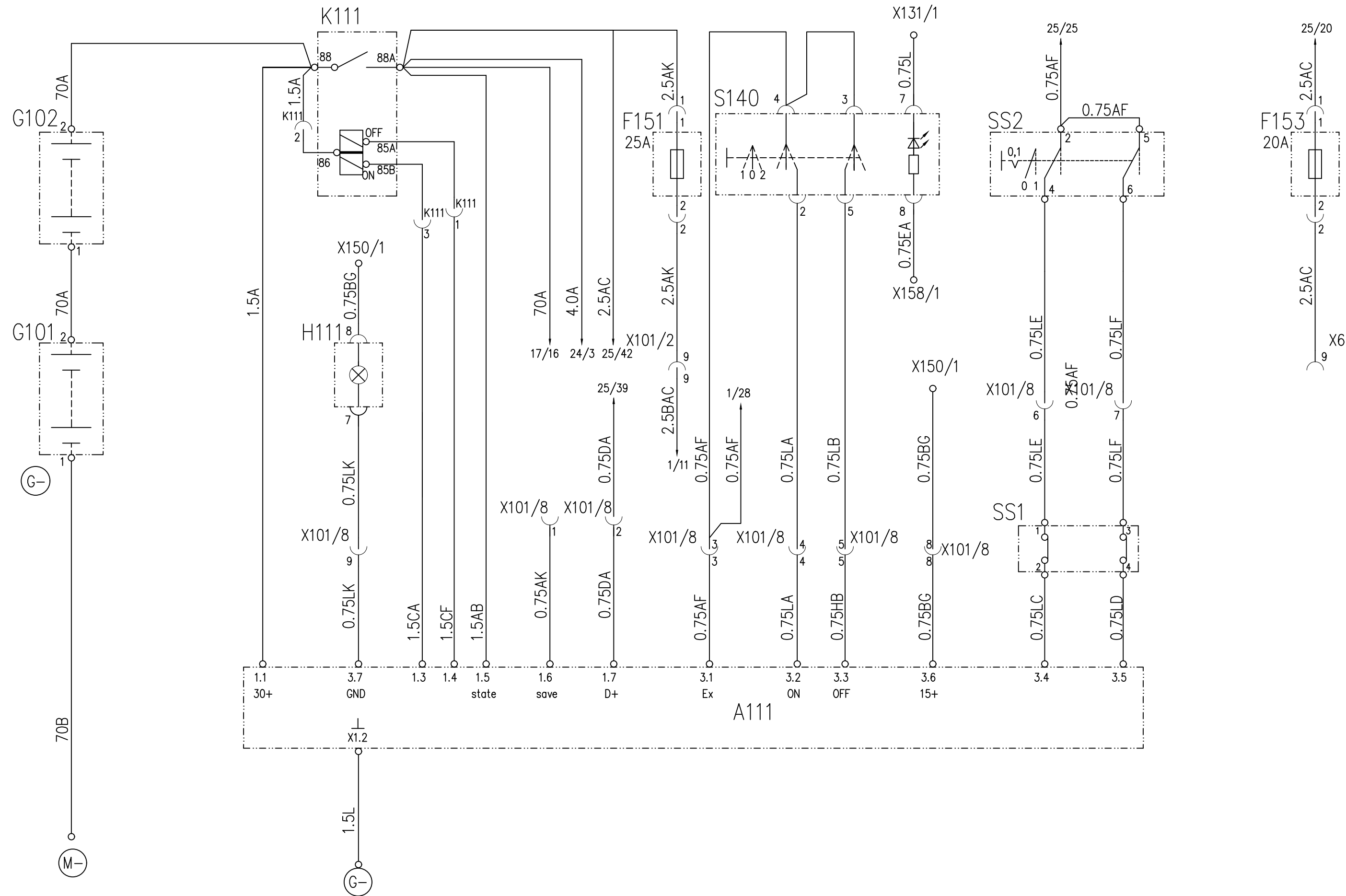

A111	ADR controller	F151	Primary electric fuse
K111	Double-wound relay	S160	ADR power switch
S140	ADR switch	SS2	Emergency power-off switch in cab
G101	Battery I	SS1	Emergency power-off switch outside cab
G102	Battery II	H111	ADR indicator light
		F153	ADR trailer fuse

Negative electrode of battery

Peripheral circuit of ADR controller

This electrical schematic diagram shows the technical status of this model as of July 30, 2022. Subject to change without prior notice.

Mark	No. of Pieces	File No.	Signature	Date

DSGN			
REWD			
CHKD			
STD.			
Process			
CTSG			
APPR			

Drawing Mark	Qty.	Scale
Trial	Small	Finished
pages in total		Page
China National heavy Duty Truck Group Co., Ltd.		

Electrical Schematic Diagram of SITRAK-C7H Vehicles (Nano+TFT) (Ver. 2022-01)-26

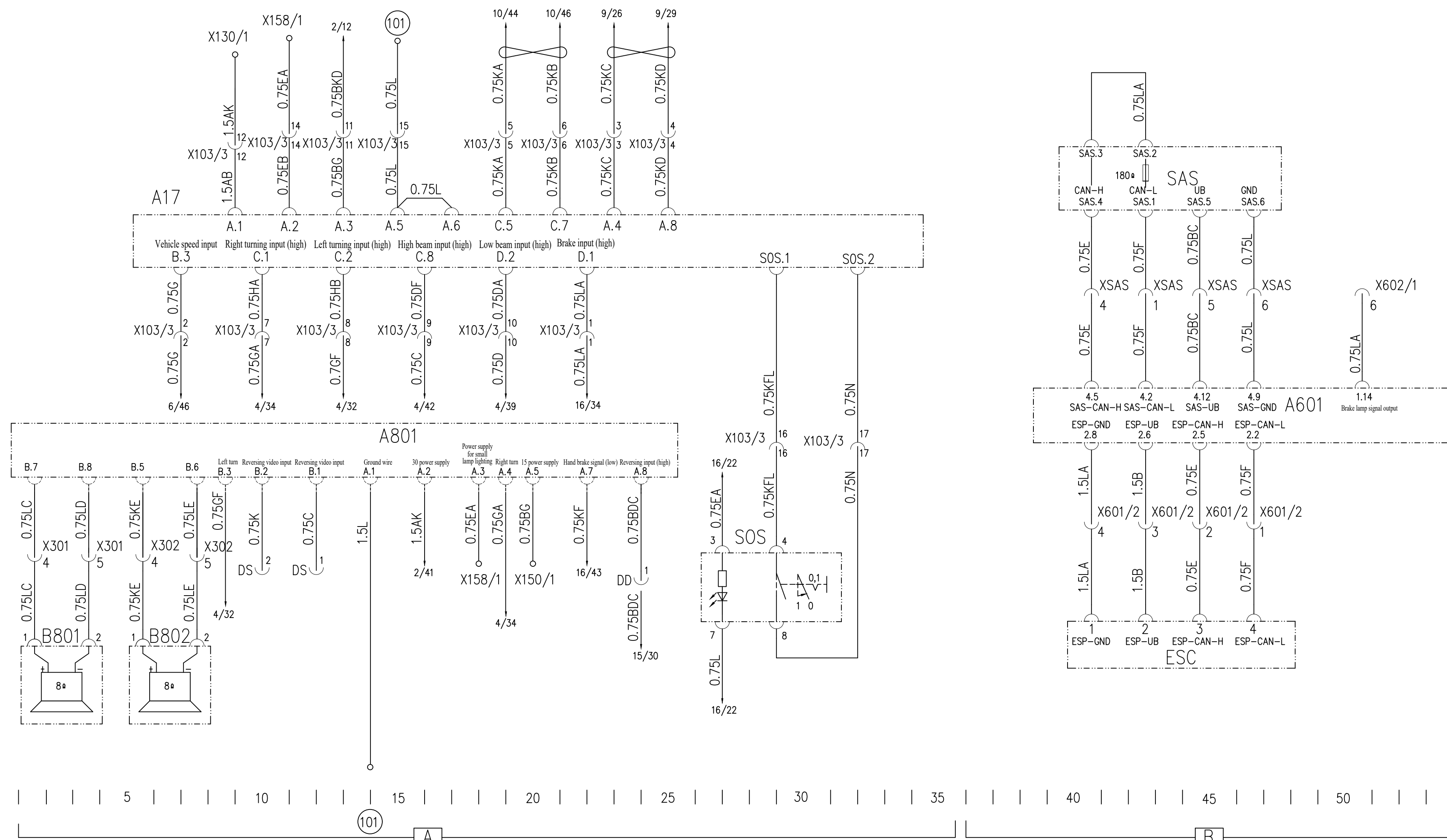

A110	Overvoltage alarming device	B802	Internal speaker at right door		
A17	Vehicle monitoring equipment assembly	F813	DC/DC fuse		
A806	On-board monitoring equipment	X240	24V standby power connector		
A801	MP5	SOS	Emergency button		
B101	Vehicle speed sensor	MP5	Touch screen MP5		
B801	Internal speaker at left door				

(102) Bonding point at co-driver's side in cab

A. MP5, Beidou Recorder System VDR B. EBS System

This electrical schematic diagram shows the technical status of this model as of July 30, 2022. Subject to change without prior notice.

Mark	No. of Pieces	File No.	Signature	Date

DSGN			
REWD			
CHKD			
STD.			
Process			
CTSG			
APPR			

Drawing Mark	Qty.	Scale
Trial	Small	Finished
pages in total		Page
China National heavy Duty Truck Group Co., Ltd.		

Electrical Schematic Diagram of SITRAK-C7H Vehicles (Nano+TFT) (Ver. 2022-01)-27

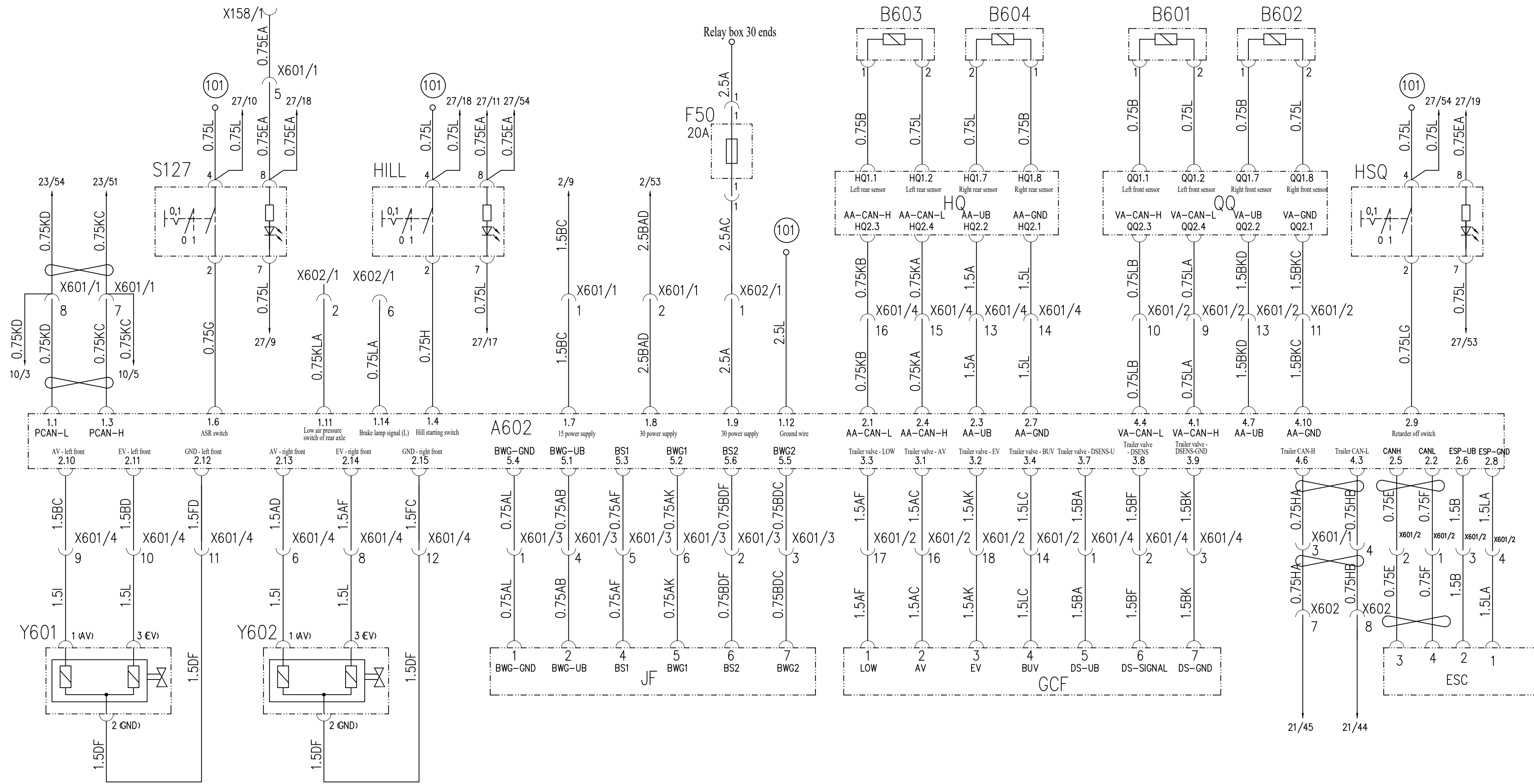

5 | 10 | 15 | 20 | 25 | 30 | 35 | 40 | 45 | 50

A602	EBS controller	S127	ASR switch	HQ	Rear axle module
B601	Left front wheel sensor	HILL	Hill starting switch on/off	GCF	Trailer valve
B602	Right front wheel sensor	Y601	Left front wheel solenoid valve	X6	EBS 7-hole trailer socket
B603	Left rear wheel sensor	Y602	Right front wheel solenoid valve		
B604	Right rear wheel sensor	HSQ	Retarder off switch		
JF	Foot valve	QQ	Front axle module		

(101) Bonding point at right cab side

A. EBS3 Peripheral Wiring Diagram WABCO
B Trailer EBS Socket

This electrical schematic diagram shows the technical status of this model as of July 30, 2022. Subject to change without prior notice.

Mark	No. of Pieces	File No.	Signature	Date

DSGN			
REWD			
CHKD			
STD.			
Process			
CTSG			
APPR			

Electrical Schematic Diagram of SITRAK-C7H Vehicles (Nano+TFT) (Ver. 2022-01)-28

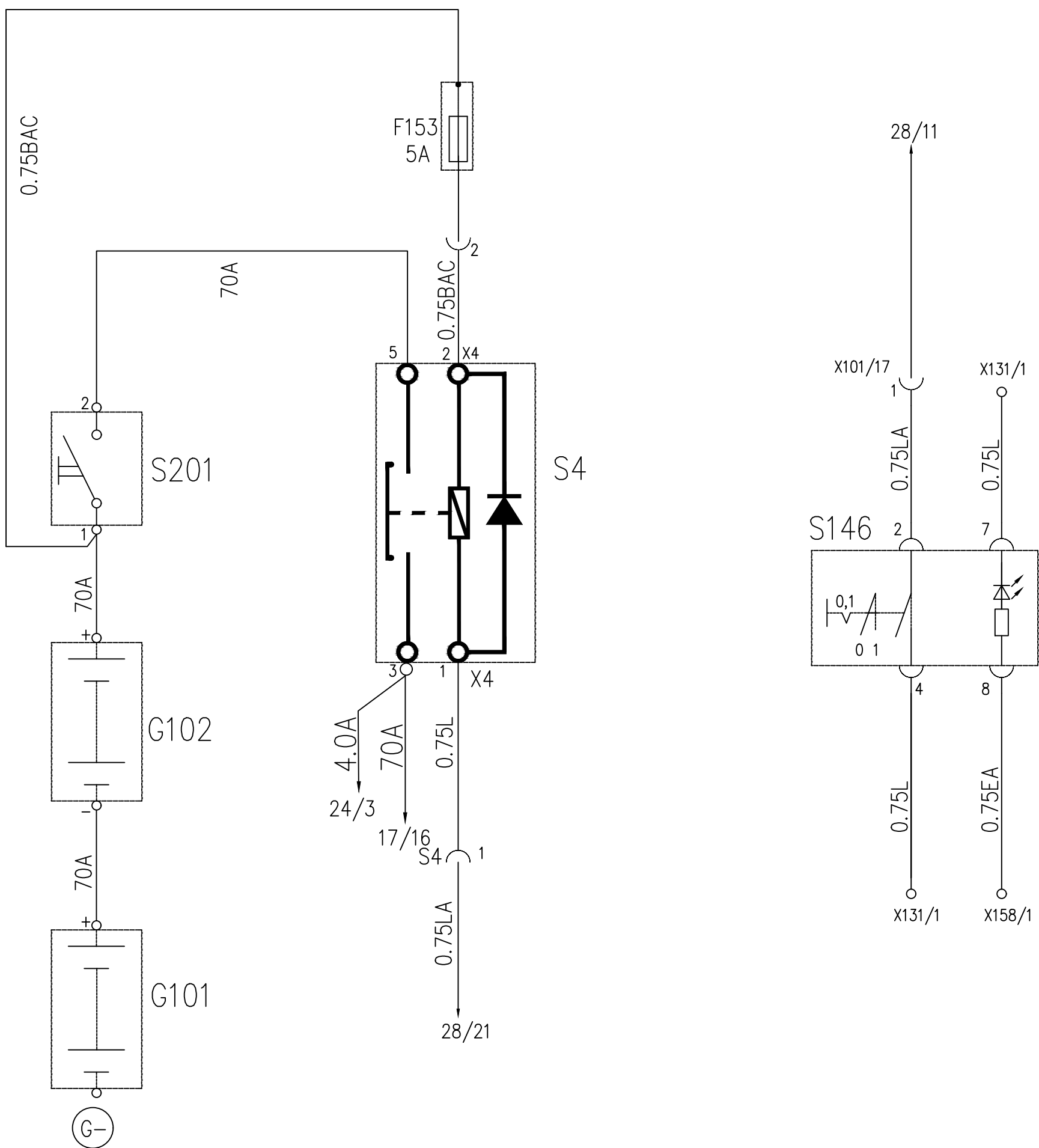

This electrical schematic diagram shows the technical status of this model as of July 30, 2022. Subject to change without prior notice.



S4	Electromagnetic main power switch						
G101	Battery I						
G102	Battery II						
S201	Main mechanical power switch						
S146	Solenoid switch						
F153	Fuse						

X158: small lamp splitter in cab

Negative electrode of battery

X131/1: ground wire splitter in cab

Mark	No. of Places	File No.	Signature	Date

DSGN			Dual power switch	Drawing Mark			Qty.	Scale
REWD								
CHKD								
STD.								
Process				A total of 43 sheets			Sheet 1	
CTSG				China National heavy Duty Truck Group Co., Ltd.				
APPR								

Electrical Schematic Diagram of SITRAK-C7H Vehicles (Nano+TFT) (Ver. 2022-01)-29

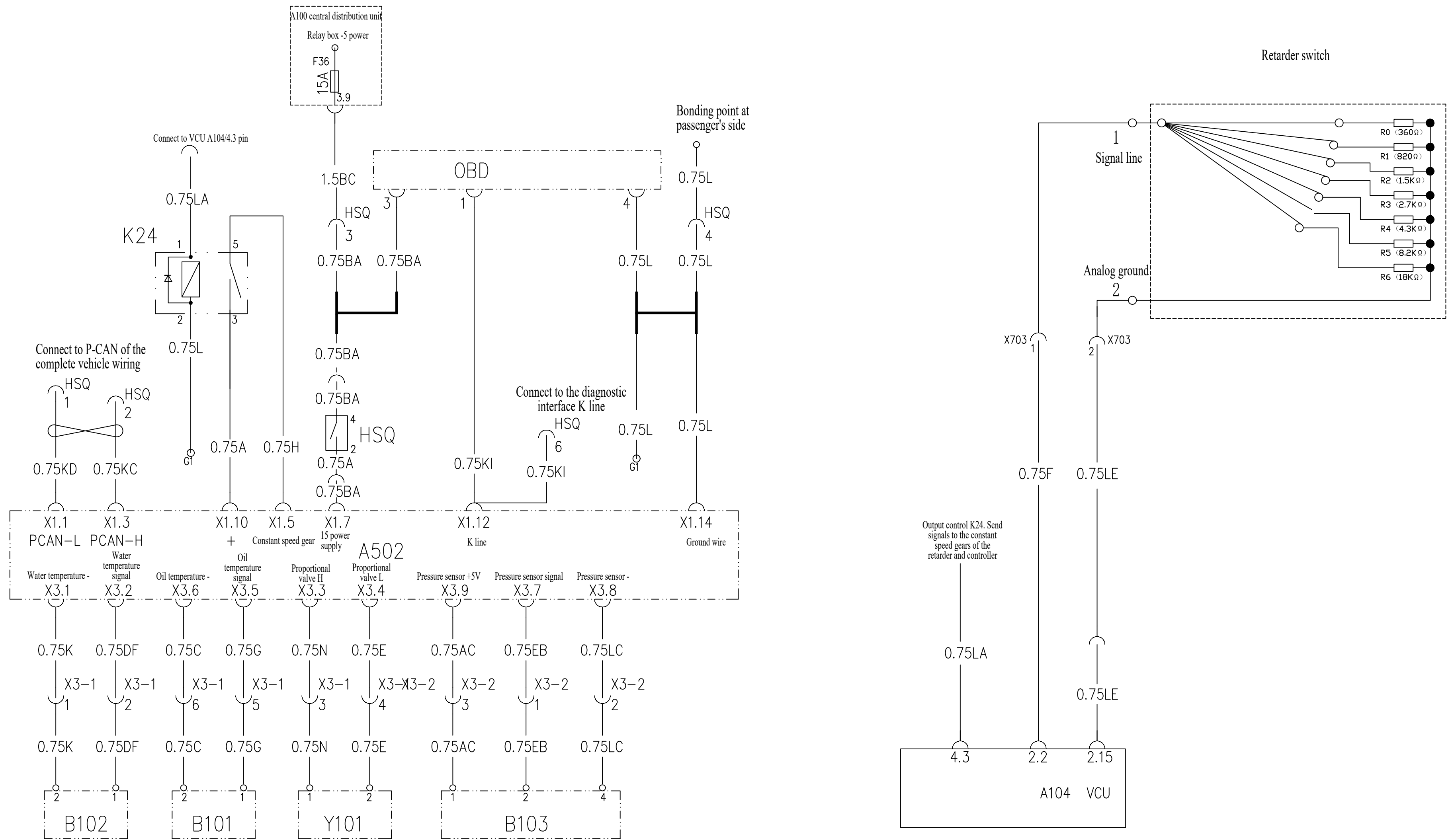

- A502 Voith retarder ECU
- K24 Constant speed gear relay
- B101 Oil temperature sensor
- A104 VCU controller
- B102 Water temperature sensor
- B103 Pressure sensor
- Y101 Proportional valve

Mark	No. of Places	File No.	Signature	Date

	DSGN		
	REWD		
	CHKD		
	STD.		
	Process		
	CTSG		
	APPR		

Additional Schematic Diagram of C7H Retarder (Voith)

712-99192-1313

Drawing Mark	Qty.	Scale

of 1 Sheet 1
China National heavy Duty Truck Group Co., Ltd.

712-99192-1312

Electrical Schematic Diagram of SITRAK-C7H Vehicles (Nano+TFT) (Ver. 2022-01)-30

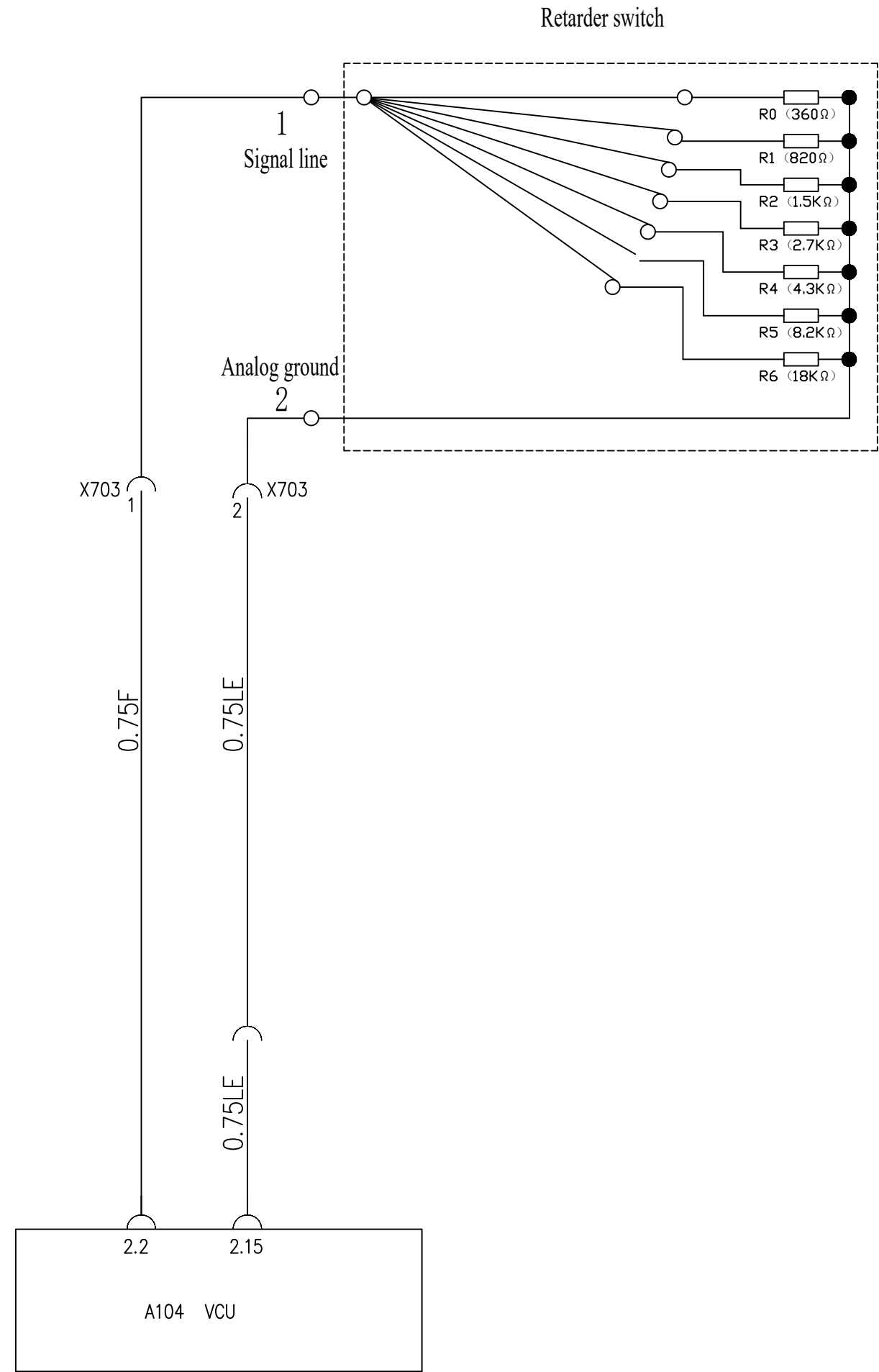
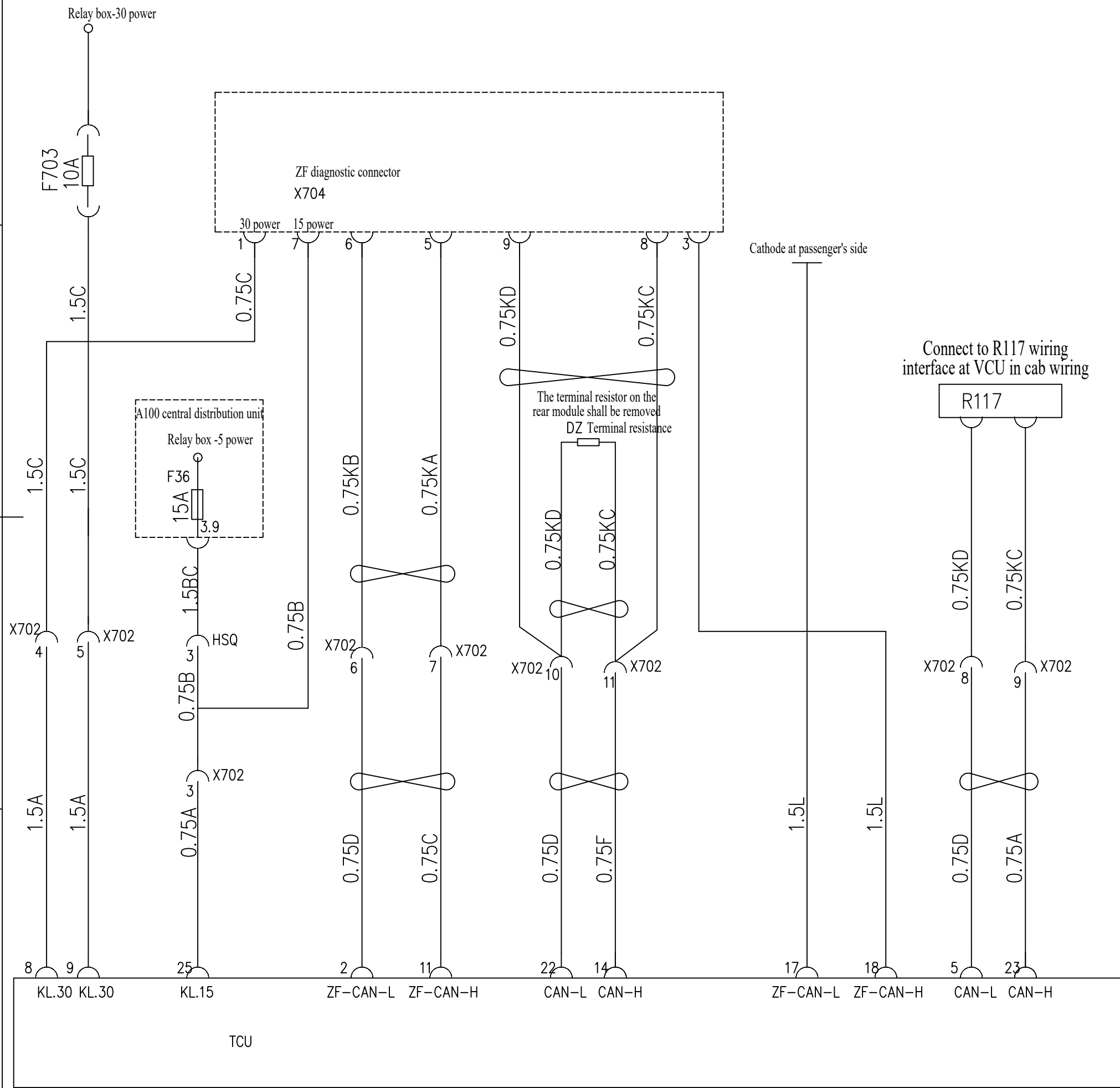

X704 ZF diagnosis connector
 A100 Central distribution unit
 A104 VCU controller

Mark	No. of Places	File No.	Signature	Date

	DSGN		
	REWD		
	CHKD		
	STD.		
	Process		
	CTSG		
	APPR		

Additional Schematic Diagram of Retarder

712-99192-1312

Drawing Mark	Qty.	Scale
Trial		

of 1 Sheet 1
 China National heavy Duty Truck Group Co., Ltd.

Electrical Schematic Diagram of SITRAK-C7H Vehicles (Nano+TFT) (Ver. 2022-01)-31

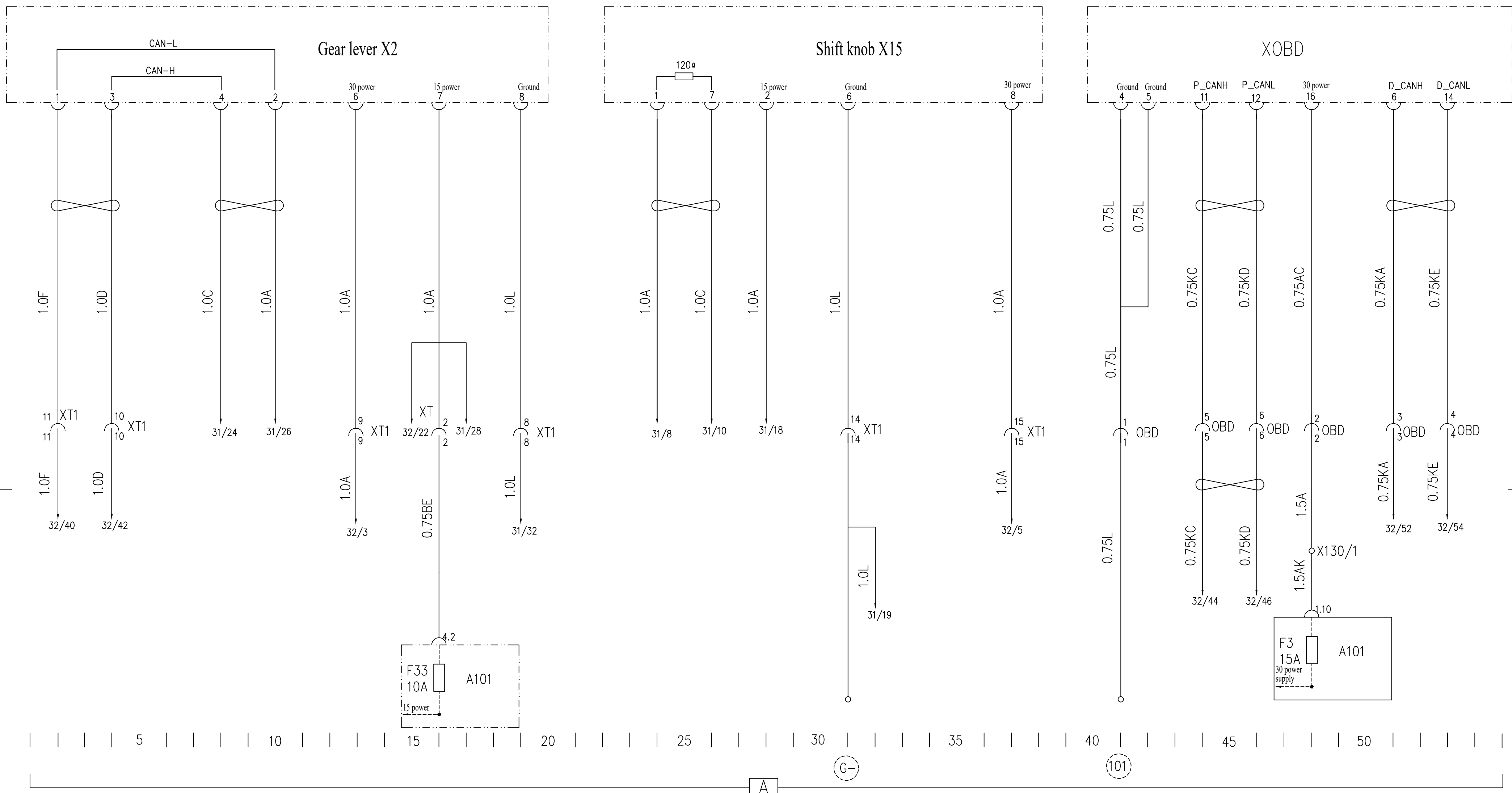

X2	Gear lever				
X15	Shift knob				
XOBD	ZF-AMT diagnostic interface				
A101	Complete vehicle electrical junction box				

- G- Negative electrode of battery
- 101 Instrument-side bonding point
- X130/1 Instrument 30 electric splitter

Mark	No. of Places	File No.	Signature	Date

	DSGN		
	REWD		
	CHKD		
	STD.		
	Process		
	CTSG		
	APPR		

Electrical Schematic Diagram of SITRAK-C7H Vehicles (Nano+TFT) (Ver. 2022-01)-32

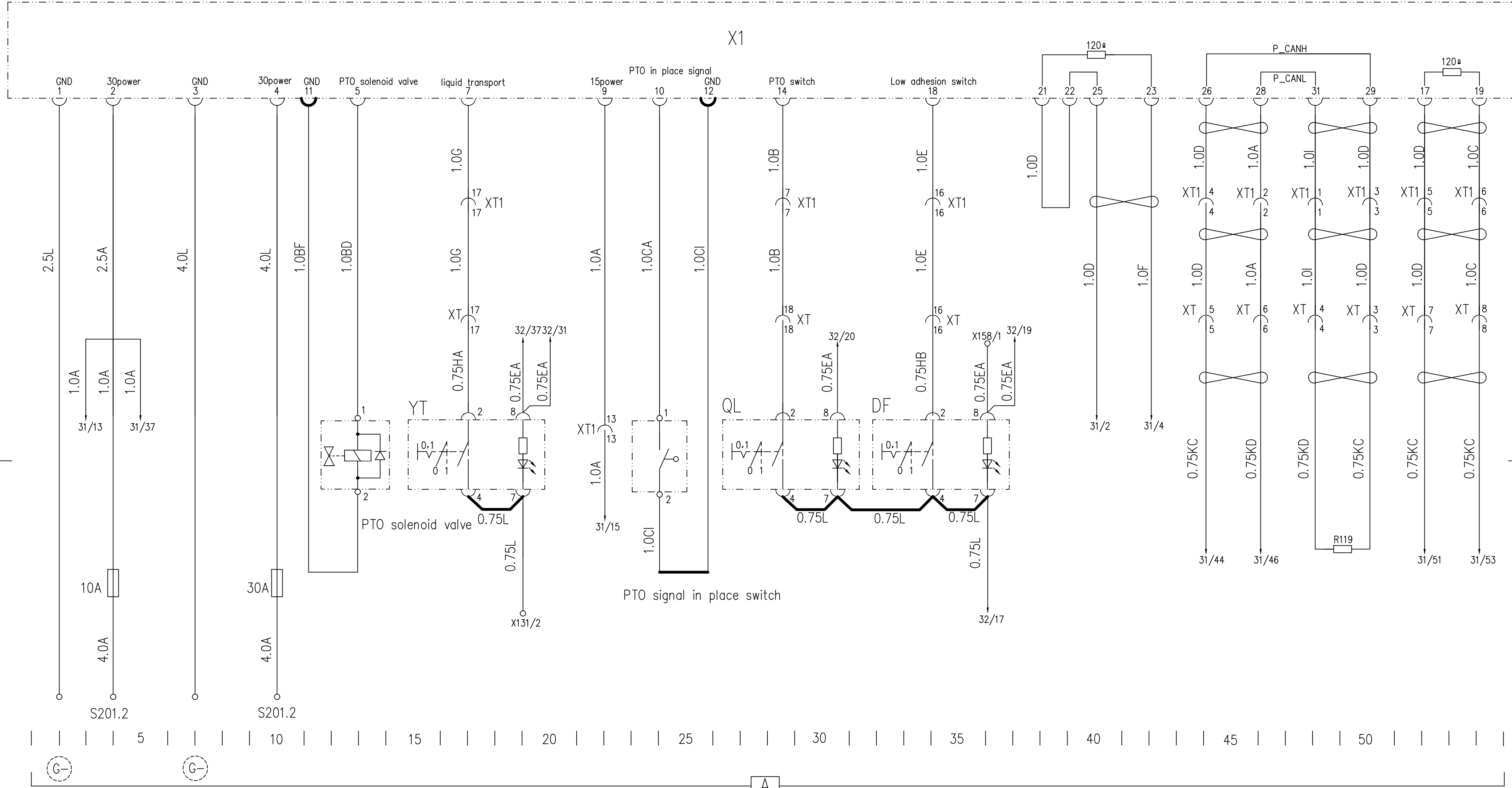

X1	ZF-AMT controller
X158/1	Vehicle mark light power divider
X131/1	Ground line divider in cab
YT	Liquid transfer switch
DF	Low adhesion switch (highway mode switch)
QL	PTO switch

(G-) Battery negative pole

S201.2 Power main switch (30power)
X158/1: Position light line divider

Mark	No. of Places	File No.	Signature	Date

	DSGN		
	REWD		
	CHKD		
	STD.		
	Process		
	CTSG		
	APPR		

Drawing Mark	Qty.	Scale

page(s) in total Page

China National heavy Duty Truck Group Co., Ltd.

Electrical Schematic Diagram of SITRAK-C7H Vehicles (Nano+TFT) (Ver. 2022-01)-34

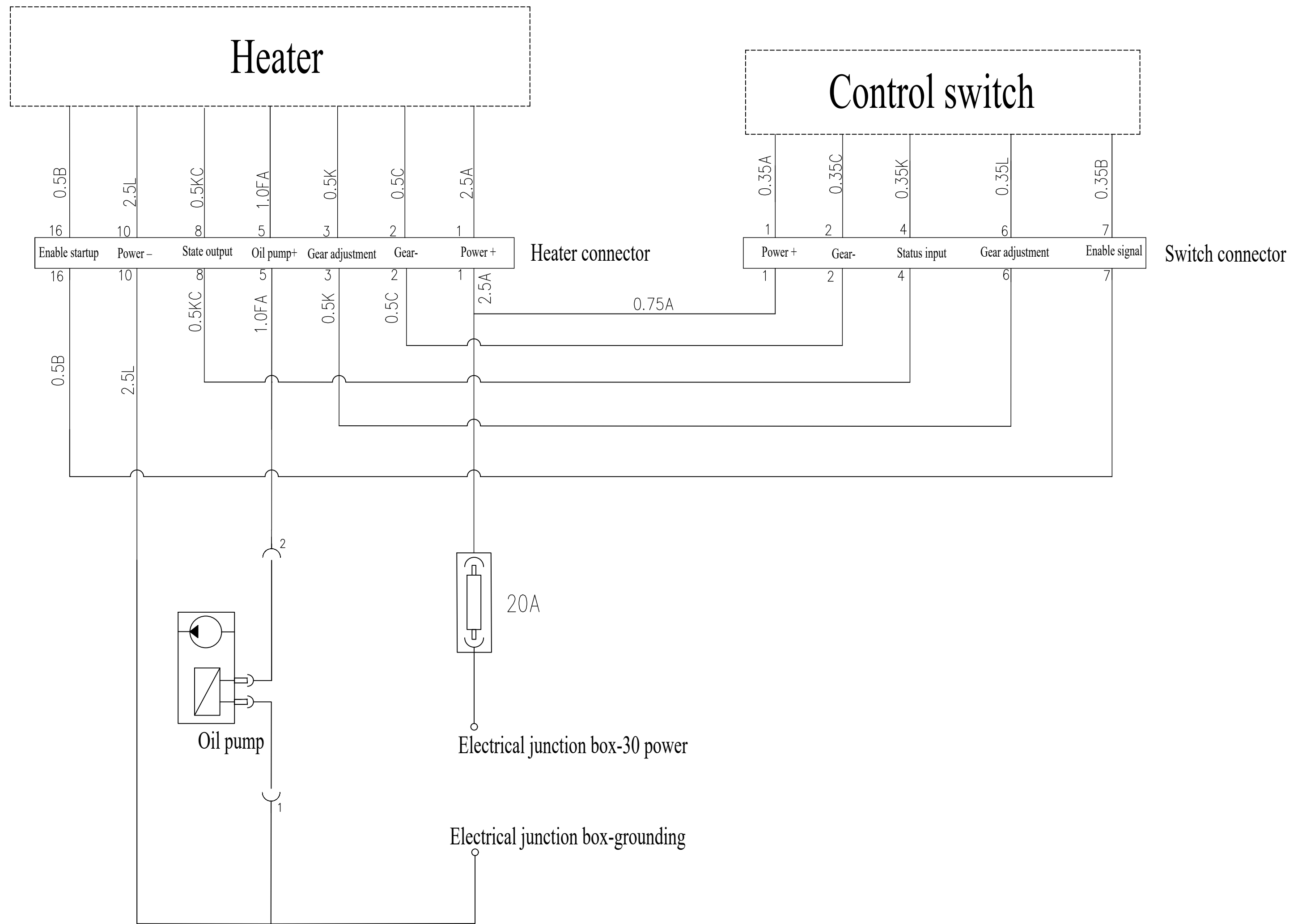

| 5 | | | 10 | | | 15 | | | 20 | | | 25 | | | 30 | | | 35 | | | 40 | | | 45 | | | 50 | | |

Mark	No. of Places	File No.	Signature	Date

DSGN			
REWD			
CHKD			
STD.			
Process			
CTSG			
APPR			
Drawing Mark		Qty.	Scale
Small			
page(s) in total		Page	
 China National heavy Duty Truck Group Co., Ltd.			

Electrical Schematic Diagram of SITRAK-C7H Vehicles (Nano+TFT) (Ver. 2022-01)-35

A103

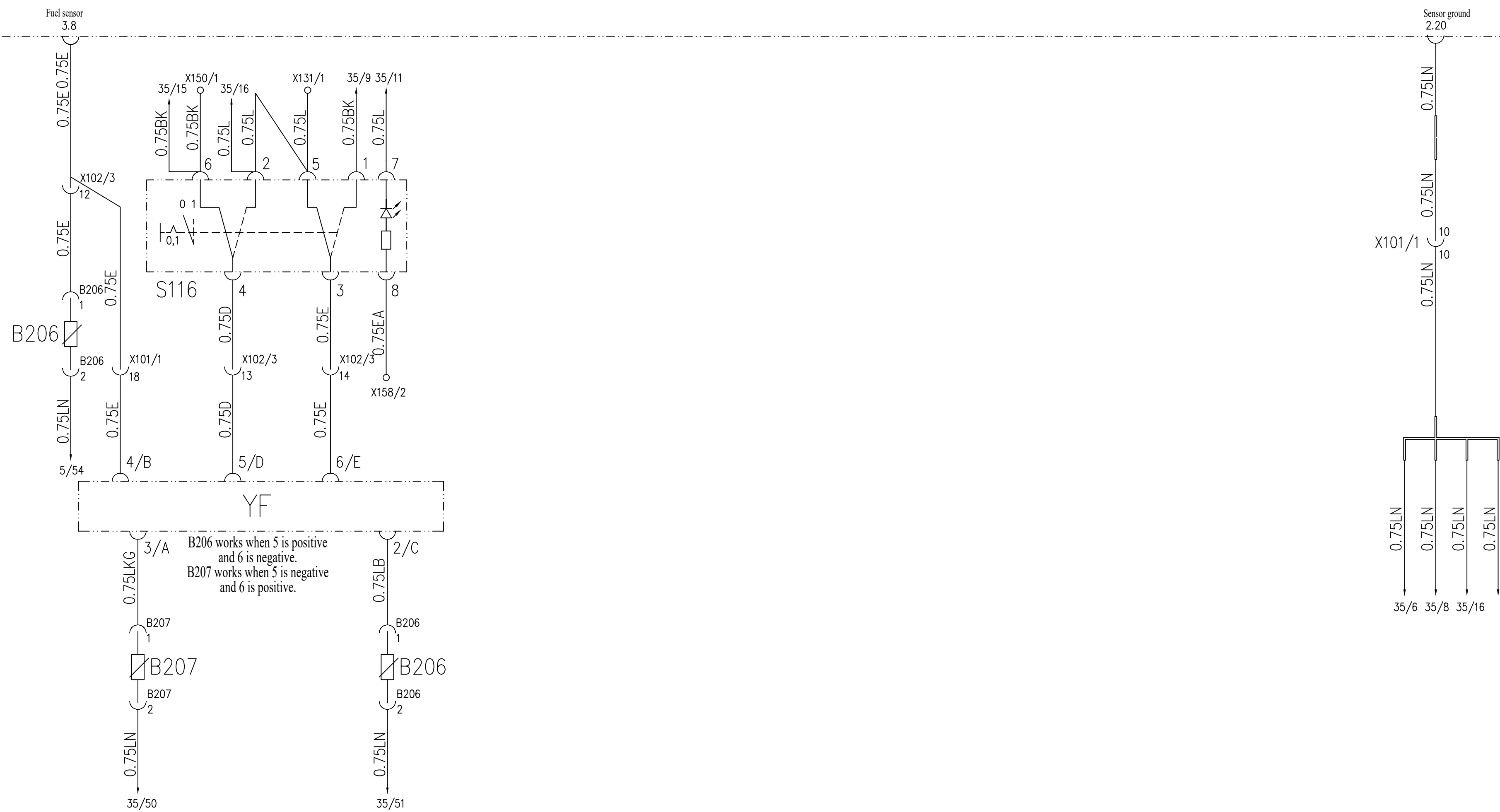

B206 works when 5 is positive and 6 is negative.
B207 works when 5 is negative and 6 is positive.

Negative electrode of battery

B206	Fuel sensor				
B207	Fuel sensor for auxiliary fuel tank				
S116	Change-over switch for main and auxiliary fuel tanks				

DSGN			
REWD			
CHKD			
STD.			
Process			
CTSG			
APPR			
Drawing Mark		Qty.	Scale
Small			
page(s) in total		Page	
 China National heavy Duty Truck Group Co., Ltd.			

Mark	No. of Places	File No.	Signature	Date

Electrical Schematic Diagram of SITRAK-C7H Vehicles (Nano+TFT) (Ver. 2022-01)-36

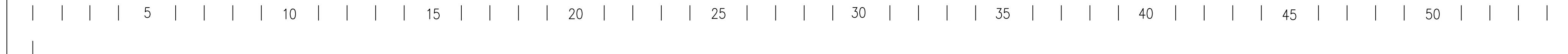
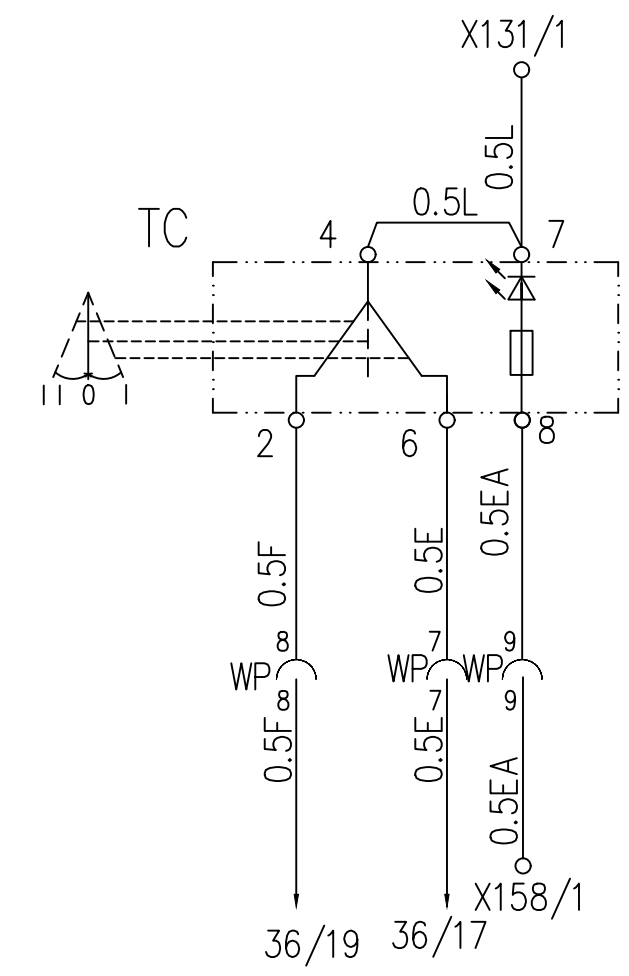
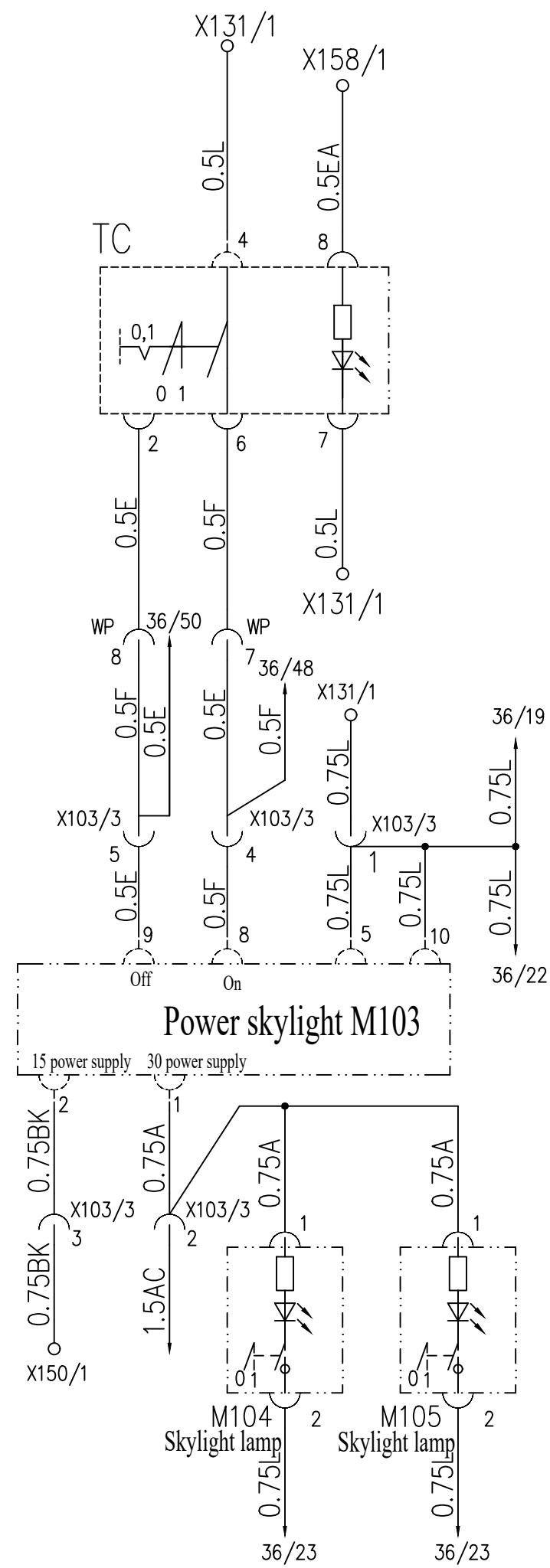

Mark	No. of Places	File No.	Signature	Date

DSGN			
REWD			
CHKD			
STD.			
Process			
CTSG			
APPR			
Drawing Mark		Qty.	Scale
Small			
page(s) in total		Page	
 China National heavy Duty Truck Group Co., Ltd.			

Electrical Schematic Diagram of SITRAK-C7H Vehicles (Nano+TFT) (Ver. 2022-01)-37

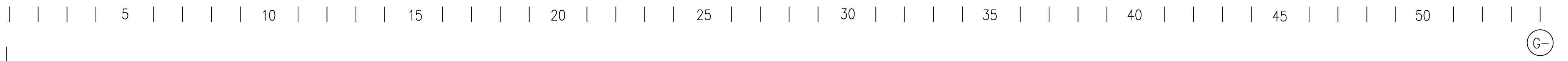
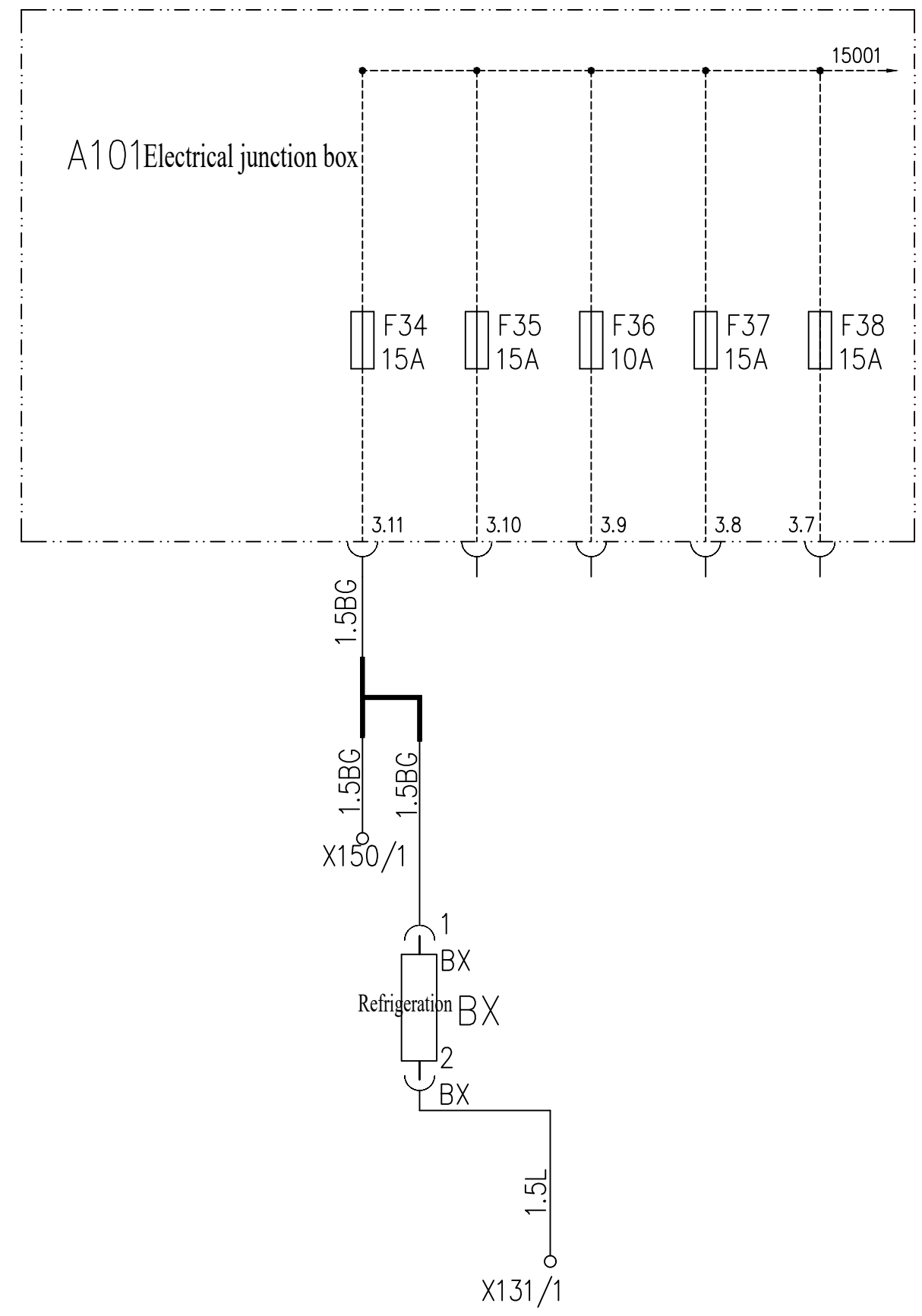

X131/1 ground wire splitter

Mark	No. of Places	File No.	Signature	Date

	DSGN		
	REWD		
	CHKD		
	STD.		
	Process		
	CTSG		
	APPR		

Drawing Mark		Qty.	Scale
page(s) in total		Page	
China National heavy Duty Truck Group Co., Ltd.			

Electrical Schematic Diagram of SITRAK-C7H Vehicles (Nano+TFT) (Ver. 2022-01)-39

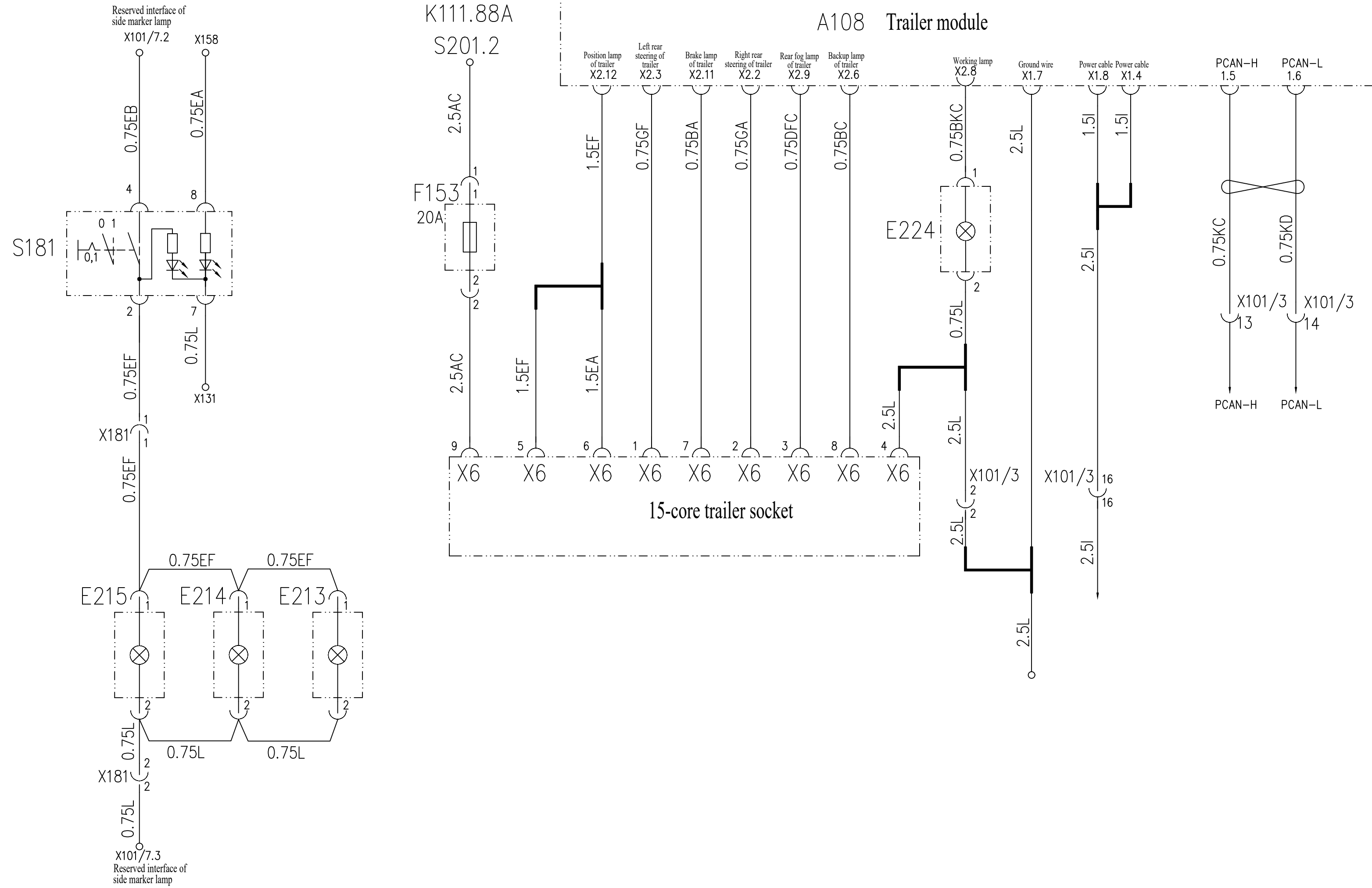

5 | 10 | 15 | 20 | 25 | 30 | 35 | 40 | 45 | 50

(G-)

(G-) Negative electrode of battery

Metal bumper trailer is provided with trailer module and trailer marker lamp

A108	Trailer module	E213	Left marker lamp of trailer		
F153	20A fuse	E214	Medium marker lamp of trailer		
E224	Working lamp	E215	Right marker lamp of trailer		
X6	Trailer socket	S181	Marker lamp switch of trailer		

DSGN			
REWD			
CHKD			
STD.			
Process			
CTSG			
APPR			

Drawing Mark	Qty.	Scale

of 60 Sheet 56

China National heavy Duty Truck Group Co., Ltd.

Mark	No. of Places	File No.	Signature	Date

F

F